



# USER GUIDE

## **2000 Family DC / Temperature Source Instruments**



---

## Warranty

This Vitrek instrument is warranted against defects in material and workmanship for a period of two years after the date of purchase. Vitrek agrees to repair or replace any assembly or component (except batteries) found to be defective, under normal use, during the warranty period. Vitrek's obligation under this warranty is limited solely to repairing any such instrument, which in Vitrek's sole opinion proves to be defective within the scope of the warranty, when returned to the factory or to an authorized service center. Transportation to the factory or service center is to be prepaid by the purchaser. Shipment should not be made without prior authorization by Vitrek.

This warranty does not apply to any products repaired or altered by persons not authorized by Vitrek or not in accordance with instructions provided by Vitrek. If the instrument is defective as a result of misuse, improper repair, or abnormal conditions or operations, repairs will be billed at cost.

Vitrek assumes no responsibility for its product being used in a hazardous or dangerous manner, either alone or in conjunction with other equipment. Special disclaimers apply to this instrument. Vitrek assumes no liability for secondary charges or consequential damages, and, in any event, Vitrek's liability for breach of warranty under any contract or otherwise, shall not exceed the original purchase price of the specific instrument shipped and against which a claim is made.

Any recommendations made by Vitrek or its representatives, for use of its products are based upon tests believed to be reliable, but Vitrek makes no warranties of the results to be obtained. This warranty is in lieu of all other warranties, expressed or implied and no representative or person is authorized to represent or assume for Vitrek any liability in connection with the sale of our products other than set forth herein.

Instrument Serial Number: \_\_\_\_\_

Document Part Number MO-2000-M Revision C

## Copyright

Copyright© 2019 Vitrek. All rights reserved.

All rights reserved. No part of this publication may be reproduced, transmitted, transcribed, stored in a retrieval system, or translated into any language in any form with prior written consent from Vitrek. This product's user guide is copyrighted and contains proprietary information, which is subject to change without notice. The product displays and instructional text may be used or copied only in accordance with the terms of the license agreement.



XITRON is a trademark of Vitrek. All other trademarks or registered trademarks are acknowledged as the exclusive property of their respective owners.

In the interest of continued product development, Vitrek reserves the right to make changes in this guide and the product it describes at any time, without notice or obligation.

## Vitrek

12169 Kirkham Road  
Poway, CA 92064  
Telephone: 858-689-2755  
Email: [info@vitrek.com](mailto:info@vitrek.com)

# Contents

Warranty	3
Introduction	9
Product Description	9
Features	10
Front Panel Controls and Connections	11
Display	11
“POWER” Switch	11
Battery Indicators	12
Red “BATT CHG” Light	12
Green “OK” Light	12
“OUTPUT” Terminals	12
Keypad	13
Numeric Keys	13
+/- Key	13
Arrow Keys	13
Multiplier Keys	13
Units/Enter Keys	14
“CLR” Key	14
“MNU” Key	14
Rear Panel Connections and Controls	15
Charging Connector	15
Compensated Thermocouple Connection	15
Interface Connectors	16
2000-IE-BAT Connector	16
2000-RS-BAT Connector	16
Rear Panel Switch	16
Charging the Battery	19
The Internal Battery	19

To Charge the Battery _____	19
Charging Status _____	20
Charging from the Charging Module _____	20
Charging Modules _____	21
Charging from an External DC Voltage Supply _____	22
Continuous Power from External Supply _____	22
Operating the 2000 Instrument _____	23
Front Panel Operation _____	23
Initial Power Application _____	23
Connecting to the OUTPUT Terminals _____	24
Displaying Instrument Status _____	24
Numeric Data Entry _____	26
Direct Entry of Required Output Level _____	27
Changing Displayed Multiplier _____	28
Direct Entry of Temperature Data _____	29
Reversing Polarity of the Present Output Level _____	29
Adjusting Output Level or Simulated Temperature _____	30
Increasing or Decreasing Output Level _____	31
Changing Adjustment Value _____	32
Terminating Adjust mode _____	32
Selecting Default Power on Condition _____	32
Range Locking _____	33
Calculating Output Mode of Operation _____	34
Selecting Measurement Mode _____	37
Deselecting Measurement Mode _____	37
Rear Panel Operation _____	38
Using Thermocouple Simulation _____	38
Deselecting Thermocouple Simulation Mode _____	41
Using the Memory Options _____	43
Memory Organization _____	43
Front Panel Memory _____	43
Rear Panel Memory _____	45
General Memory Considerations _____	46
Applications _____	48
Low-level DC Power _____	48
Ensuring Stable Voltage Connections _____	49

---

Ensuring Stable Current Connections _____	50
Process Control Industry Applications _____	52
Calibrating in Process Control Environments _____	52
Simulating Thermocouple Systems _____	55
Measuring Thermocouple Outputs _____	56
Engineering Laboratory Environment Applications _____	57
Calibration and Maintenance _____	61
Internal Calibration _____	61
External Calibration _____	62
Equipment Required to Recalibrate _____	62
Initiating External Calibration _____	64
Performing External Calibration _____	65
Periodic Maintenance _____	71
Internal Maintenance _____	72
Replacing the Internal Battery _____	73
Interface Operation _____	75
RS232 Interface Option _____	75
Selecting RS232 _____	76
RS232 Handshake Lines _____	76
IEEE488 Interface Option _____	76
Remote/Local Operation _____	77
Address Selection _____	77
IEEE488 Handshake Lines _____	77
Bus Commands _____	78
Other IEEE488 Specific Items _____	78
Reading Data Via an Interface _____	79
Sending Data Via an Interface _____	79
Command Set for the 2000 Instrument _____	79
Keypress, Simulation Command Characters _____	79
Firmware Version F.02 _____	81
Extended Command Set _____	81
Command String Usage _____	82
Setting an Output Voltage or Current _____	82
Adjusting Output Level _____	83
Reading Present Output Level _____	83
Internal Calibration _____	83
External Calibration _____	84

Appendix A– Output Specifications _____	85
DC Voltage Output Specifications _____	85
DC Current Output Specifications _____	86
Voltage Measurement Specifications _____	87
Thermocouple Specifications _____	87
Appendix B– General Specifications _____	93
Warm-Up Time _____	94
Environmental _____	94
Isolation _____	94
Computation _____	94

## Tables

Table 1: Resistance Values for Transfer	58
Table 2: Voltage Accuracy Margins	62
Table 3: Current Accuracy Margins	63
Table 4: Command Characters	80
Table 5: Shortcut Command Character Sequences	80
Table 6: Extended Command Set	81
Table 7: DC Voltage Output	85
Table 8: DC Current Output	86
Table 9: Thermocouple Simulation and Measurement Specifications	88
Table 10: CJC Stability-Simulation and Measurement	89 & 90



# Introduction

This chapter describes the 2000I, 2000M, 2000IN and 2000MN DC power source instruments and highlights their features and functionalities. The 2000 instruments were introduced in 1989 to support the fields of Process Control, Calibration, and General Equipment Testing.

## Product Description

The 2000I, 2000M, 2000IN and 2000MN products are portable, lightweight DC power source instruments. Their capabilities include the generation of precision bipolar DC voltages<sup>1</sup>; precision bipolar DC currents<sup>2</sup>; the high accuracy simulation of a variety of thermocouple types with optional active cold junction compensation; and measurement of voltage and thermocouple outputs. On a 2000 instrument, you may enter a scaling factor, an offset factor and a “units” text string, which enables the calibration of four 20mA loops in the “actual” units and scaling of the transducer. Optional IEEE488 or RS232 isolated interfaces further enhance the 2000 instruments, allowing them to be used in varying applications.

The 2000I, 2000M, 2000IN and 2000MN 2000MN instruments use microprocessor and digital-analog conversion technologies to produce highly flexible, accurate instruments with high reliability. The combination of HCMOS microprocessor technologies with low-power precision analog circuitry yields a long battery life while maintaining a lightweight rugged package and a 0.5ppm analog output resolution.

Automatic internal calibration and simple front panel (covers on) external calibration maintain high accuracy. A comprehensive range of computational abilities enable a variety of applications.

---

<sup>1</sup> DC voltage expands up to 22V and down to 10nV resolution

<sup>2</sup> DC current expands up to 22mA and down to 10pA resolution

**Note:** To ensure full use of this instrument, review this complete user guide at setup.

## Features

- Fully bi-polar DC voltage and current output capability.
- DC output of 22 volts at 10ppm accuracy and 22mA at 40ppm accuracy.
- Temperature simulation with 0.01 degree resolution, 0.03 – 0.06 degree accuracy.
- Temperature measurement with 0.1 – 0.2 degree accuracy.
- Auto cold-junction compensation.
- Battery or line operation.
- Suited for “in field” calibration requirements of the process control industry.
- Portable for use in remote sites.
- Functions as a “transducer replacement” with computed output levels and enabled data entry in: psi, KPa, mmHg, and g/sec units.
- Able to calibrate at the “sending” unit.
- 2000M and 2000MN instruments perform thermocouple simulations.
- Connects in parallel with a transducer 4 -20mA output enabling to modify its output interfaces.
- Small size and weight
- Low noise performance

IEEE488: Full Talk/Listen capabilities. Isolated from output circuitry up to 500V peak

RS232: Full Talk/Listen capabilities. Selectable baud of 1200 or 19,200 baud. Isolated from output circuitry up to 500V peak.

## Front Panel Controls and Connections

This chapter discusses the basic use of the various controls, connectors and indicators on the front panel of the 2000I, 2000M, 2000IN and 2000MN DC power source instruments. Before using your instrument refer to the text on *Charging the Battery*. For a complete discussion on the methods used to perform specific tasks refer to *Front Panel Operation*.

### Display

The 2000 Families DC power source instrument display is a 16 character, single line reflective liquid crystal (LCD). This display shows selectable status or the present output of the instrument.

During interactive sequences the display enables you to select a mode and enter a value for your desired output, calculation or measurement.



The 2000 Instrument

### “POWER” Switch

This toggle switch controls the power applied to the circuitry in the instrument. Note that the charging module is always connected to the charging control circuitry in the instrument, thus the POWER switch does not control the charging of the battery.

When the POWER switch is toggled up, in the ON position, the microprocessor and analog circuitry is powered and the instrument may be operated normally. The power source may be either from the battery or the charging module, as applicable. When the power switch is toggled down, in the OFF position, the only operation enabled is charging the internal battery.

## Battery Indicators

These indicators reflect the status of the lead-acid battery (2000I, 2000M) and the Nickel Metal Hydride batteries used (2000IN and 2000MN).

### Red “BATT CHG” Light

This red light (LED) illuminates when the internal battery is being charged. Upon full charge this light extinguishes.

### Green “OK” Light

This green light (LED) illuminates when the power switch is turned on for 2000I and 2000M. For the 2000IN and 2000MN products, the Green LED is used as a Fuel Status indicator as well as showing that the unit is powered on. It is recommended that the unit is plugged in to the supplied power supply when the Green LED begins to flash

**Note:** To continue using if the light extinguishes, connect the instrument to a charging module or an external DC supply, turn the unit off and then back on to reset the internal cutoff circuitry.

## “OUTPUT” Terminals

All output voltages, currents and temperatures are available from this pair of binding posts mounted on the instrument's front panel. These terminals, one red, one black, accept banana plugs, spade leads or wires, as required.

## Keypad

These 20 keys are used for all manual entries into the instrument and to initiate any required actions. These keys are in the following groups:

### Numeric Keys

These keys: “0, 1, 2, 3, 4, 5, 6, 7, 8, 9,” and “.” are used to enter numeric data into the instrument. While the display is showing the actual output level, these keys initiate a numeric entry of a new output level; this entry will be completed by pressing the required unit’s key.

### +/- Key

The change sign (+/-) key may be used during a numeric entry to change the polarity of the entered data. If this key is pressed while the actual output level is being displayed (i.e., when not in a numeric entry) then the output level is reversed (i.e., the output polarity is changed).

### Arrow Keys

During a menu selection, and during the “Adjust” mode, the “2, 4, 6 and 8” keys are arrow keys, which scroll through various actions that show in the display.

These keys are used to select the previous displayed action.	4 key has a ◀ (left arrow)
	2 key has a ▼ (down arrow)
These keys are used to select the next action.	6 key has a ▶ (right arrow)
	8 key has an ▲ (up arrow)

To abort the selection of an activity and return the instrument to its previous condition, press the MNU key.

### Multiplier Keys

The “m” (milli) key and  $\mu$  (micro) key are used during a numeric entry to select the required multiplier for the entered data. If the m key is pressed then the entered numeric is divided by one thousand. If the  $\mu$  key is pressed then the entered data is divided by one million.

Note that prior to selecting the required units key, an entered multiplier may be changed by pressing the other multiplier or cleared by pressing the multiplier key a second time. Pressing a multiplier key while an actual output level or measured input level is being displayed (i.e., not during numeric entry) changes the display.

- If the multiplier key is different from the display, then the display format changes to use the selected multiplier.
- If the multiplier key is the same as the display, it *toggles* the usage of the selected multiplier in the display format.

## Units/Enter Keys

The V, A, °C and °F keys are encircled within a white line on the keypad. These keys are used to output in the selected units, which terminates a numeric entry. They can also select the displayed action. For example in “Measure” mode (2000M only) the V, A, °C and °F keys are used to change the displayed units of the measured data.

## “CLR” Key

This key is used to reinitiate a numeric entry (i.e., clear the display ready for restarting the entry), or during a choice selection, this key aborts the action in progress. During the “Adjust” mode of operation, this key deselected that mode with the output remaining at the present level.

## “MNU” Key

This key is used to select one of the “*special*” activities of the instrument. When initially pressed, you are prompted to select the desired action. Press any of the keys that have an arrow (2, 4, 6 or 8) to scroll through the textual options to display the required selection and then press a unit's key to execute it.

---

# Rear Panel Connections and Controls

This chapter discusses the basic use of the various controls and connectors located on the rear panel of the 2000I, 2000M, 2000IN and 2000MN power source instruments. For a complete discussion of the methods used to perform specific tasks refer to *Front Panel Operation*.

## Charging Connector

This connector, located on the rear panel in the lower right-hand corner, is the receptacle for the connector of the charging module. See *Charging the Battery* for further details regarding the usage of this connector.

**Important Note:** When connecting a charger other than that provided by Vitrek, ensure the selected charger's output voltage is: 12V at 1.5A and the center conductor is positive polarity and uses 2.5mm DC plug.

## Compensated Thermocouple Connection

This thermocouple output and measurement connections are only present on the 2000M and 2000MN instruments. Use this connection whenever the active cold junction compensation (CJC) mode of thermocouple simulation or measurement is being used.

This thermocouple connection, located in the lower center back of the instrument, is wired in parallel with the output terminals on the front panel. Thus normal output voltages or currents can be obtained using an uncompensated connection.

During calibration of thermocouple measuring instruments, be sure to use thermocouple wire between the 2000M or 2000MN instrument and the unit being calibrated.

## Interface Connectors

A connector slot is available at the top center in the back panel. A connector in this location is only present when either of the interface options IE-BAT or RS-BAT is fitted in the instrument.

### IE-BAT Connector

This is a standard IEEE488 connector, and is fitted if option IE-BAT is fitted in the instrument. The usage of this connector and the method of using the IEEE488 interface are fully described in the *Interface Operations* chapter.

### RS-BAT Connector

This is a female 9-pin sub-miniature D type connector, and contains the RS232 connections for the RS-BAT option of the instrument. The connections are as follows:

1. Data Carrier Detect (Output from instrument)
2. Transmit Data (Output from instrument)
3. Receive Data (Input to instrument)
4. Data Terminal Ready (Input to instrument)
5. Ground (Common return for these signals)
6. Data Set Ready (Output from instrument)
7. Request To Send (Input to instrument)
8. Clear To Send (Output from instrument)
9. Ring Indicate (Output from instrument)

**Note:** These connections enable using a straight through connected cable to an IBM AT® compatible RS232 connector. Use of this connector and the RS232 interface is fully described in the *Interface Operations* chapter.

### Rear Panel Switch

The rear-panel mounted *toggle* switch is only present when the IE-BAT option is fitted in the instrument. When ON (up position), the internal interface is enabled for operation and is disabled when OFF (down position).



Note that the battery life is considerably shortened when the IE-BAT Interface is enabled, thus it is highly recommended that this switch be maintained in the OFF (down) position whenever this interface is not being used. The IE-BAT Interface is only usable when this switch is in the ON position.



---

# Charging the Battery

This chapter discusses the methods available for charging the internal battery and for continuously powering the 2000 instruments from an AC power supply.

**Note:** Charge the battery with the IE-BAT interface option enabled, although the time taken to recharge will be extended when the instrument is in this condition.

## The Internal Battery

The 2000 instruments are powered from an internal sealed lead-acid battery (2000I and 2000M) or a Nickel Metal Hydride battery for the 2000IN and 2000MN product builds. The battery is fully charged when shipped from Vitrek. During shipping or storage the battery may discharge. We recommend the battery be recharged for at least 12 hours prior to its initial use. Use the charging unit provided Vitrek to charge the internal battery and to operate this instrument. Ensure that the included charging unit is compatible with your local power ratings and socket connection.

**Caution:** If using an external DC supply other than the provided charger ensure the selected charger's output voltage is: 12V at 1.5A and the center conductor is positive polarity, the DC connector is a 2.5mm Power Jack.

## To Charge the Battery

A full charge to the internal battery is achieved by inserting the small plug of the charging unit into the socket in a recess of the rear panel and then plugging the charging unit into a suitable AC power outlet.

## Charging Status

For battery charge status, refer to the front panel's red BATT CHG light.

- If the BATT CHG light extinguishes then the battery is fully charged.
- If the BATT CHG light does not extinguish after several hours of charging, turn the unit OFF and back ON (2000I and 2000M Only).
- If the light remains illuminated then continue to charge the unit for a few more hours and retry turning the unit OFF and back ON.
- And if the light still does not extinguish then replace the unit's battery.

## Charging from the Charging Module

If the internal battery has become discharged, recharge it by plugging the DC output plug on the Charging Module's cable end into the recessed receptacle on the instrument's rear panel and plugging the Charging Module into the local AC supply. Ensure that the voltage rating of the Charging Module is in accordance with the local AC supply voltage.

**Note:** For the fastest possible recharging time, place the front panel POWER switch in the OFF position.

While charging the internal battery, the BATT CHG light will be illuminated. When this LED becomes extinguished, the internal battery is fully charged.

The instrument can be operated while it's charging. Note that when doing so, to fully charge the internal battery may take up to 15 hours. If the instrument is not operated during charging then a full charge will take up to 12 hours.

**Caution:** If the instrument is connected to other circuitry or instrumentation when the Charging Module is connected, ensure that less than 500V of common mode potential to ground is present; **SEVERE DAMAGE** could result if excessive common mode voltages are present.

**Warning:** Prior to recharging the internal battery disconnect the 2000 instrument from any intrinsically-safe process control system. Charging while connected could adversely affect the safety of the process control system.

## Charging Modules

One of these modules is included with the main unit (as specified at the time of order). Additional charging modules may be obtained using the codes described below.

### **“M02000”**

This option delivers an additional copy of this user guide. If not included at the time of placing the order for the basic unit, please have the serial number of your unit available when making this order.

### **“MS2000”**

This option delivers a full service manual, incorporating schematics, assembly diagrams, fault diagnosis aids and full servicing information. If not included at the time of placing the order for the basic unit, please have the serial number of your unit available when making this order.

### **“SP48”**

A 48” long shielded cable with low thermal spade lugs terminating each lead. Use this leads for applications requiring superior performance at levels below  $1\mu\text{V}$ .

### **“PL36”**

A 36” long shielded cable with low thermal plugs terminating each lead. This lead should be used for applications requiring superior performance at levels below  $1\mu\text{V}$ .

### **“T1”**

A wall-mount charger with 120VAC input and 12VDC @ 1.5A minimum output. (This version has been obsoleted; The T5 is the recommended replacement)

## “T5”

A free-standing, universal charger with 85VAC - 265VAC input and 12VDC @ 1.5A minimum output.

## Charging from an External DC Voltage Supply

Similarly, the instrument may have its internal battery charged from an external DC voltage supply of between 10V and 15V, with at least 1.5A of drive capability. If this is desired, obtain a DC power jack, which meets the requirements of 2.5mm pin diameter and 5.5mm external diameter. For example: Switchcraft® 760. The center pin connector should be a positive potential connection, note that internal circuitry prevents damage from polarity reversal.

The DC power supply used may be any laboratory type of power supply or alternatively a 12V lead-acid battery (e.g., an automobile battery). This latter method for recharging the internal battery in the instrument yields the useful feature of allowing you to recharge the instrument from an automobile (e.g., the cigarette lighter), thus you may take the instrument into remote locations (or locations where the local AC supply is unknown) without the concern of recharging the internal battery.

## Continuous Power from External Supply

The charging module or an external DC supply may be left continuously applied without damage to the 2000 instrument. It is recommended that for the 2000I and 2000M products the unit is allowed to discharge completely to reduce the memory effect of the Lead Acid battery. Vitrek recommends using an external DC supply for process control applications.

<p><b>Warning:</b> Unless the charging source is an external battery, continuous operation from an external supply when the instrument is connected to a process control system may degrade the safety of that system.</p>
--

---

# Operating the 2000 Instrument

This chapter discusses operating the 2000I, 2000M, 2000IN and 2000MN DC power source instruments. Throughout this chapter, the instrument is assumed to be a 2000M or 2000MN, which has full capabilities, described in this User Guide. If data is entered for which the option is not fitted, then a message displays for two seconds, and the entry is discarded.

## Front Panel Operation

The 2000 instrument's front panel provides the user interface for the following functions: power ON; DC power output; mode selection; data entry, edit and recall; measurement; and calibration. Note that recall of steps is covered in the *Using the Memory Options* chapter and calibration is covered in *Calibration and Maintenance*. Additional 2000 instrument uses are covered in the *Applications* chapter.

## Initial Power Application

Shortly after the POWER switch is toggled to the ON position, the display will show the model number and the latest firmware version.

### Example: Version: F:03

During the display of this data, the internal microprocessor performs tests upon the internal circuitry. If any faults are detected, then a message describing the fault will be displayed. Dependant on the nature of the fault, the instrument will either display the message for approximately two seconds prior to the instrument continuing with normal operation or hold the displayed message. In this instance—no further operation of the instrument is possible until the fault has been corrected.

When the POWER switch is placed in the OFF position, the terminals remain in the condition prevailing. Vitrek recommends selecting the “Stand-by” state prior to switching the POWER switch OFF, to afford the highest level of protection both to any circuitry connected to the instrument and to protect the instrument from inadvertent application of external signals.

## Connecting to the OUTPUT Terminals

To deliver voltage, current, or temperature to your test equipment, connect it to the binding-post terminals using banana plugs, spade leads or wire. When a positive polarity of output is requested, the RED terminal is the positive terminal and has the requested current flow.

### **Notes:**

- 1) The terminals are automatically configured as input terminals when the 2000M instrument is set to the “Measure” mode.
- 2) In cold junction compensation mode (CJC), the output connectors are wired in parallel with a female rear-panel mounted connector.

## Displaying Instrument Status

The DC calibrator instrument offers the flexibility of setting the output level and setting the instrument's status to “Standby” or “Operate”. This is done following the application of power. The display shows the output level and status following the messages associated with the power on internal tests. With the instrument in the user-selectable “Standby” mode, the output connectors are disconnected internally.

The following example is seen in “Operate” status, which means the output level is actually being produced at the output terminals of the instrument. Examples of the output level and status displays are:

**< +10.00000mV >**

The following example is seen in “Standby” status, which means the output terminals are open circuited internally.

**<+ 10.00000mV Stby >**



The displayed output level will be present when the instrument returns to “Operate” status.

## Displaying Mode Options

The menu-selectable modes display the opposite selection that is presently active in the instrument. For instance:

- When “Select Operate” displays, the instrument is actually in “Standby”.
- When “Select Standby” displays, the instrument is actually in the “Operate” mode.
- When “Start Adjust” displays, the instrument is in the “End Adjust” or “Operate” mode.
- When “End Adjust” displays, the instrument is actually in “Adjust” mode.
- When “Lock . . . Rng” displays, the instrument may be in “Unlock . . . Rng” or the “Operate” or “Standby” mode.
- When “Use Active CJC” displays, when the instrument is in “Passive CJC” or “Operate” mode.
- When “Use Passive CJ” displays, the instrument is actually in “Active CJC”.

## Selecting “Operate” or “Standby”

In “Standby” mode the 2000 instrument internally opens its output terminals. This ensures you and the instrument itself are safe from current and voltage. When the instrument is in the “Standby” state the characters “Stby” are displayed at the right-hand end of the display. When the instrument is in the “Operate” state then this area is blank in the display format.

- *To change the mode from “Operate” to “Standby” (or vice versa):*
  1. Press the MNU key. Depending on the mode, the display will show one of the following:
 

**< Select Operate > or < Select Standby >**
  2. Press any of the Units/Enter keys (V, A, °C or °F) to display the output (value) in terms of the displayed mode.

3. The display then returns to displaying the selected output level and mode. The output terminals will either be open circuit—if “Standby” was selected, or at the requested output level—if “Operate” was selected.

**Caution:** Prior to selecting the “Operate” mode, check the displayed output level. If the connected external circuitry is incompatible with the selected output level, then this circuitry could be damaged when changing to “Operate” mode.

## Numeric Data Entry

At various places in the following procedures, the user is requested to provide numeric data input to the instrument, this paragraph describes the actions required.

Numeric data entry is initiated by pressing a numeric key on the front panel (i.e., the digit keys 0 through 9 or the decimal point key). The display then shows the entered numeric in the left-most character position of the display and the remaining portions of the display will be blank. The cursor will automatically move to under next possible character entry point, showing the position into which the next key press will be placed. (Leading zeroes, prior to a decimal point or prior to a non-zero numeric, are ignored.)

Up to 7 digits plus a decimal point may be entered, entries beyond this are ignored. If no decimal point has been pressed, it is assumed to be following the last digit pressed (e.g., an entry of **124** is equivalent to an entry of **124.0**).

The multiplier keys (m and u) may be used during numeric entries. Thus entries of **0.001** and **1m** are equivalent. Note that certain entries must use a multiplier, e.g., if an entry of **0.00000012** is desired, then this must be entered as **0.12μ**.

If an error is made during numeric entry then several options exist for correcting the data, prior to terminating the entry. The steps are the same for a new entry or during a prompted entry.

- **To correct a data entry error:**
  1. Press the CLR key. This initializes the entry point either to a blank area or the previous data.



Note that the output level is displayed using the same multiplier as used during the entry of the output level, thus entries of: **1V**, **1000mV** and **1000000uV**.

Each achieve an output level of: **1V**, but the display format will differ. Note also that the selection of polarity should be made during the entry of the numeric data, pressing the +/- key before pressing any numeric keys causes the present output level to reverse its polarity.

**Caution:** For voltage outputs always specify value in millivolts to prevent damage to equipment.

If the entered output level is beyond the capabilities of the instrument, then the closest possible output level is selected, and a warning message is displayed for approximately two seconds.

## Changing Displayed Multiplier

The output level is displayed using the same multiplier used during the data entry. Pressing the same multiplier key as is presently displayed will deselect the multiplier.

To reformat the display data use the multiplier keys to select the desired format for the output level. Pressing the multiplier key that is not presently displayed, reformats the display. See the examples below.

- ***To deselect the multiplier:***

1. For example: if the display is: **+10.00000mV**
2. Press the **m** key to change the display to: **+0.0100000 V**

- ***To use the selected multiplier:***

1. For example: if the display is: **+10.00uV**
2. Press the **m** key to reformat the display to: **+0.01000mV**

And

1. For example: if the display is: **+1.000000 V**
2. Press the  $\mu$  key to reformat the display to: **+100000.  $\mu$ V**

## Direct Entry of Temperature Data

The temperature of the hot junction of the thermocouple system to be simulated may be directly entered similarly to entering output voltage or current. The difference is that the display format is fixed. And although the multiplier may be used numerically during the entry, the display format is unaffected.

For example: If **120m°C** is entered, then a temperature of **0.12°C** will be selected. The display format used for temperature simulations also includes information regarding the thermocouple type.

Examples of the format used are:

**+1000.00°C R**      and      **+1000.00°F R**

In both cases, the selected thermocouple type is "R". For details on the method used to select the thermocouple type, cold junction compensation technique and cold junction temperature, refer to *Thermocouple Simulation or Measurement Set-Up* paragraph.

## Reversing Polarity of the Present Output Level

As previously mentioned, the polarity of the present output level (or simulated temperature) may be reversed by simply pressing the +/- key.

1. If the displayed output level is: **+1.000000 V**
2. Press the +/- key to change the output level to: **-1.000000 V**

And

1. If the displayed simulated temperature is: **+100.00°C R**

2. Press the +/- key to change the simulated temperature to: **-100.00°C R**

Note that unlike voltage or current output levels, the limits of available simulation temperatures are not identical in both polarities (in general). If the attempted temperature exceeds these limits, then the simulation temperature will be set to the limit at the requested polarity and a warning message will be displayed for approximately two seconds.

## Adjusting Output Level or Simulated Temperature

The 2000 instruments allow you to incrementally step up, or down, the output level and to incrementally step up, or down, the hot junction simulation temperature. Use this “Adjust” mode to perform calibration of an external unit of equipment. During a calibration procedure the 2000 instrument will display each modified output level of the equipment being calibrated. This function allows for any error in the equipment to be highlighted. This section describes the method used to perform this action.

- **To access “Adjust” mode:**
  1. Press the MNU key and then an arrow key: 2, 4, 6, or 8 repetitively until the adjust choice displays: **< Start Adjust >**
  2. Press any of the Units/Enter keys (V, A, °C or °F) to select the “Adjust” mode. The display then returns to displaying the selected output level, with the least significant displayed digit flashing (showing the size of the increment that will be used).

During the “Adjust” mode of operation, the following changes to the display format occur:

- The display no longer shows the “Stby” characters at the right hand end of the display when in “Standby” mode.
- The multiplier is automatically selected to provide the required resolution in the display. The previously described ability to control the multiplier used in the display format is inactive.
- The thermocouple type data is no longer provided in the display.

- The amount by which the output has been deviated from the initial value is shown in the display.

The level present when the “Adjust” mode was initiated is referred to as the *nominal* output in this document. Examples of display formats during “Adjust” mode are shown below, with the increment digit underlined for clarity.

- If the initial output level is: **-1.0 V** and no adjustment had taken place, then the display shows: **1.00000V + 0.00μV**
- If the initial output level is: **+10.0mV**, and the output is adjusted to: **10.028mV**, then the display shows: **+10.0280m - 280μV**.

The displayed deviation shows the amount the item being calibrated is in error. Specifically it shows the opposite polarity to the amount the output level was deviated, thus the *nominal* value is the addition of the actual output level and the displayed deviation. The deviation always displays using the lowest possible multiplier, therefore:

- A voltage deviation of up to **999uV** is displayed using the **μ** multiplier.
- A voltage deviation of up to **999mV** is displayed using the **m** multiplier, and
- A voltage greater than **999mV** is displayed *without* a multiplier.

Current output levels and deviations are displayed similarly to the voltage output levels and deviations shown above, with the exception that the deviation multiplier may be **p**, **n**, **μ** or **m** as required. Note that only **μ** and **m** are Units/Enter keys.

An example of a simulated temperature deviation is shown below. Note that the format is slightly different from a voltage or current output in that multipliers are not used for either the deviation or the simulated temperature. The maximum deviation possible is: **+/- 99.99°C** or **°F**. Any attempt to deviate a temperature beyond this limit will be ignored: **+1000.00+10.00°C**

## Increasing or Decreasing Output Level

After the “Adjust” mode has been initiated, the output level or simulated temperature may be increased or decreased by using the, **8 ▲** (up arrow) key or

2 ▼ (down arrow) key. The output level or simulated temperature is incremented or reduced by the value of the selected (flashing) digit with full under/ and overflow carry to the remaining digits (including carry through zero).

## Changing Adjustment Value

As explained in the preceding paragraph, the output level (or simulated temperature) is adjusted by the value of the flashing digit in the display. This can be adjusted, within the constraints of the displayed value, by pressing the 4 ◀ (left arrow) key, which moves the adjustment digit to the left, or the 6 ▶ (right arrow) key, which moves the adjustment digit to the right. Any attempt to shift the adjustment digit out of the present display window is ignored.

## Terminating Adjust mode

Terminating the “Adjust” mode of operation is achieved using the MNU key once and arrow keys repetitively. Here, the display shows the action as:

**< End Adjust >**

After selection of this action, the output level and status display return to their normal format. The output level, or simulation temperature, returns to the nominal value, the value that was present when the “Adjust” mode was initiated.

The “Adjust” mode may be terminated by pressing the CLR key, which leaves the output level unchanged.

## Selecting Default Power on Condition

The 2000 instruments allow you to define the state and output level at which the instrument will commence operation following application of power. The sequence required to select the desired output level and status are described below.

- Press the MNU key. A menu displays, prompting you to select either the “Standby” or “Operate” state.



- If neither “Standby” or “Operate” are the desired action at this point, continue to press any of the arrow keys, or the MNU key until the “Set Defaults” action is displayed: **< Set Defaults >**
- Press any of the Units/Enter keys (V, A, °C or °F) to select this action. The display then prompts to select whether the instrument is to assume the “Operate” or “Standby” state, following power on, the display shows: **< Select Standby >**
- If the “Operate” mode is required, then press any of the arrow keys to select the alternate action: **< Select Operate >**
- When the desired action displays, press any of the Units/Enter keys (V, A, °C or °F) to select the action required. The display then shows the present default output level, similar to that shown in the example: **+1.000000 V**
- This shows that the output level following power on will be: **+1.0 V**
- Now enter the desired initial output level, terminating the entry by pressing the Units/Enter keys: V or A, as required.

The instrument returns to normal Operation, displaying the present output level and status. The default values set during this procedure are used when the instrument is next powered ON.

## Performing Internal and External Calibrations

Calibration is initiated via the MNU key. Refer to the *Maintenance and Calibration* chapter.

## Range Locking

The F.02 or later firmware versions provide “Range Lock” mode for the 20VDC and 2VDC, as well as for the 20mA DC current range. These range locking features provide more functionality for calibration and testing of diverse circuits such as control loops and A/D converters. In locked range mode, the accuracy/offset/resolution specifications for the selected range apply for all entered output levels, including those which would normally invoke a lower range. For precise testing with extremely small output levels, it is recommended to unlock the instrument to allow operation in Auto-Range mode.

The “Range Lock” mode can be selected by stepping through the menu, similar to the operation of all earlier firmware versions. The three possible locked ranges, 20V, 2V, and 20mA, will appear in sequence. With the desired range on the display, pressing any one of the Units/Enter keys will lock the instrument in the shown range. Unlocking the ranges can be accomplished in a similar fashion.

When in locked 20V or 20mA range, output levels below 2.2V or 2.2mA respectively, will not cause the instrument to range down. Similarly, when in 2.0V locked range, the instrument will not range down when programmed to output levels below 0.22V. The full ranges are continuous therefore, without the level switching that would occur in auto-range mode. Range locking can be made the default (power-up) mode by selecting the “Set Defaults” menu choice.

When in 2.0V locked range, the output level cannot exceed 2.2V, irrespective of the entered value. As before, when programming values which exceed the instrument's output level capability, the 2000 instruments will automatically go to “Standby” operation, as these level requests are illegal commands.

Version F.02 accepts 22mA as a valid output level, where earlier firmware versions would only accept output current commands up to 21.999mA, and would cause the instrument to revert to “Standby” state when programmed to output 22mA.

## Calculating Output Mode of Operation

The 2000I, 2000M, 2000IN and 2000MN DC power source instruments have the capacity to compute the actual output level from an *equation* entered in the specific data units of the instrument being calibrated. For example, a process controllers' 4 - 20mA input scaled to yield a 50 to 150psi range of pressure indications. Further examples of the use of this feature are given in the *Applications* chapter.

## Initiating and Setting-Up the Calculated Output Mode of Operation

The sequence of key presses required to initiate the “Calculated Output” mode of operation is as described below:

1. Press the MNU key, the display will then prompt you for selection of either the “Standby” or “Operate” state as described previously in this chapter.
2. Since neither “Standby” nor “Operate” are desired, press an arrow key until the “Calculated Output” action is displayed:

### < Calculated >

3. Then press any of the Units/Enter keys (V, A, °C or °F) to select this action.
4. The equation used by the 2000 instruments to calculate the actual output level is formed by a straight line passing through two points, which you define. These two points (called A and B) may be in any order—ascending or descending—and simply require the entry of the actual output level and the equivalent *user entry* level at each of these points.
5. The display then prompts you to enter Output A (i.e., the actual output level for point A), and displays the presently stored data. Press the corresponding units key (if this data is to be retained) or enter the desired data and units.
6. The display then prompts you to enter User Data A and displays the presently stored data. Press any units key (if this data is to be retained) or enter the desired data and then press any units key.
7. The display then prompts you to select the required user entry units. You may sequentially select (for each character position) the desired character by using the, 8 ▲ and 2 ▼ keys. Note that both upper- and lower-case characters are available and up to three characters may be specified. To terminate the selection of each character press the 6 ► key and select the next character to be entered, or press any of the Units/Enter keys (V, A, °C or °F) to terminate the entry.

**Note:** The list of available characters is as follows, in the order selected:

- The \$, %, and / characters;
  - The upper-case alphabet (i.e., A through Z);
  - The lower-case alphabet (i.e., a through z);
  - The ° and μ characters.
8. The display then prompts you to enter Output B (i.e., the actual output level for point B), and displays the presently stored data. Press any units key (if this data is to be retained) or enter the desired data followed by any units key.

Note that the units for this data are automatically those previously selected for the Output A data.

9. The display then prompts you to enter User Data B and displays the presently stored data. Press any units key (if this data is to be retained) or enter the desired data and then press any units key. Note that the units for this data are automatically those previously selected for the User Data A data.
10. Following entry of the above data, the instrument will then initiate the “Calculated Output” mode of operation.

## **Operating in the Calculated Output Mode**

Operation of the instrument while in the “Calculated Output” mode of operation is the same as that while in the normal mode of operation, with the following exceptions:

1. Numeric entries of the required output level are in the user units set during the set-up of this mode of operation, thus the unit key used to terminate the entry is discarded.
2. While a multiplier key may be used during the entry, this does not affect the display format (it is used to scale the entered data however).
3. The “Adjust” mode may be used while in “Calculated Output” mode; however, the display format is such that the user units are not displayed during the adjustment process.
4. The data points A and B may be changed while in “Calculated Output” mode by simply repeating the procedure as was used to initiate this mode. The new factors replacing those previously used. Note that these data are stored in a non-volatile manner, thus are available always, even following power-down.

## **Deselecting the Calculated Output Mode**

Deselecting the “Calculated Output” mode of operation is achieved by pressing any of the Units/Enter keys (V, A, °C or °F) without prior numeric entry. This action will deselect the “Calculated Output” mode of operation and leave the output level and type unaffected. The display will show the output level corresponding to the previously used user data. This deselecting process may be used as a check of the entered data.

## Selecting Measurement Mode

Use this mode to measure voltage or temperature of another device. With the instrument in Measure mode, the output connectors automatically reconfigure as input terminals.

- ***To select Measurement mode:***
  1. Press the MNU key to access “Operate” or “Standby” modes.
  2. If the instrument is presently in the “Operate” state, then select the “Standby” state.
  3. While in “Standby” connect the voltage or thermocouple to be measured.
  4. Press the MNU key; again and repetitively press any of the arrow keys until the “Measure” prompt displays.
  5. Press any of the Units/Enter keys to select the Measure mode.

The instrument will then begin measuring the applied voltage, converting it into the computed temperature for the selected thermocouple type.

- ***To display the measured voltage:***  
Press the V key.
- ***To show the computed temperature in the respective units.***  
Press the °C or °F key.
- ***To reformat the display using the desired multiplier:***  
Press the  $\mu$  or m keys while the display is showing the measured voltage.

## Deselecting Measurement Mode

While the instrument is in the Measure mode of operation, the “Output” mode may be selected in the following manner:

1. Press the MNU key. If the instrument is presently in the “Operate” state, then disconnect the voltage or thermocouple previously being measured.
2. Repetitively press any of the arrow keys until the “Output” prompt is displayed.
3. Press any of the Units/Enter keys to select the “Output” mode.

## Rear Panel Operation

All the connections available on the 2000 instruments rear panel are dependent on which options are *fitted*. Refer back to the *Rear Panel Connections and Controls*.

**Note:** In the 2000M instrument, the thermocouple simulation output, or thermocouple measurement input, should be taken from the connector mounted on the rear panel.

## Using Thermocouple Simulation

The type of thermocouple to be simulated or measured may be altered, whether active or passive cold junction compensation (CJC) is used, and whether the cold or reference temperature is used. Note that this data is non-volatile, thus may be selected prior to use, even if the instrument is to be powered down. This option is available in the 2000M only.

## Thermocouple Simulation and Measurement Set-Up

The 2000M instrument's thermocouple simulation capability is achieved by setting the desired simulation parameters and then commanding the required temperature outputs. Setting the simulation parameters involves the selection of the desired thermocouple type, the method of cold junction compensation, and the cold junction temperature (if "Passive CJ" has been selected).

Selecting the thermocouple type involves the using the command shortcut character T followed by the thermocouple type character. For example if a K or an N type simulation was required, then the string "TK" or "TN" respectively, would be transmitted to the instrument.

If Active CJC is required, then transmit the command string "J1" to the instrument, while passive mode is selected by the "J0" string. When changing from the active to the passive mode, the previously used passive mode reference temperature defaults.

**Notes:**

Selecting and deselecting thermocouple simulation is simply achieved by:

- 1) Sending a temperature to the instrument, for example: Send the command string “**+22.89C**” to select the thermocouple simulation mode with a simulated hot junction of **+22.89°C**.
- 2) Sending a voltage or current to the unit: for example: The command string “**+10.0V**” will set the output level to **+10V**, which deselects thermocouple simulation mode.

Always, the Thermocouple Simulation Set-Up data used is that previously defined, thus it is not necessary to redefine these parameters for each simulation temperature. Terminating thermocouple simulation is achieved by sending the unit a voltage or current output level command, or by sending the “V” command string without any numeric data. In this case, the output level simply stays at the previously Calculated voltage, but terminates thermocouple simulation.

- ***To achieve Thermocouple Simulation:***

1. Press the MNU key, the display will prompt you to select either the “Standby” or “Operate” state.
2. Press any arrow key repeatedly until either one of the following appears:

**< Use Active CJC >**      or      **< Use Passive CJ >**

3. If the instrument is (presently) set to use active CJC the display will read: “Use Passive CJ”. This feature allows you to select the opposite mode.
4. If the displayed selection is required, then press any of the Units/Enter keys (V, A, °C or °F), otherwise press the CLR key to abort the selection.

- ***To achieve Thermocouple Measurement Set-Up:***

1. Press the MNU key and the display will prompt you to select either the “Standby” or “Operate” state.

3. Neither “Standby” nor “Operate” are desired actions, therefore continue to press any of the arrow keys repeatedly until the “Thermocouple” set up action is displayed. **< Thermocouple >**
4. Press any of the Units/Enter keys (V, A, °C or °F) to select “Thermocouple”.
5. The display then shows the default thermocouple type to be simulated similarly to the display shown below. Here a type “R” thermocouple is to be simulated. **< Type-BEJNRST >**
6. Then select the required default thermocouple type to be simulated by repeatedly pressing the 4 ◀ (left arrow) or 6 ▶ (right arrow) keys until the required thermocouple type is underlined. The selection is then made by pressing any of the Units/Enter (V, A, °C or °F) keys.
7. If “Active CJC” has been selected, then the unit will return to normal operation, displaying the present output level and status. If the instrument is presently performing a thermocouple simulation, then this data will be used immediately, or it will be used when the temperature to be simulated is entered. Otherwise, the instrument prompts you to enter the reference junction's (reference) temperature for thermocouple simulations.
8. The display will show the presently stored data similarly to: **+1000.00°C**
9. Next enter the required default reference temperature.
10. Terminate the entry by pressing the required Units/Enter keys (°C or °F).

**Notes:**

- 1) If a single junction thermocouple is to be simulated, you can select either 0°C or 32°F as the reference temperature. The hot junction temperatures will be entered as the temperature rise of this junction goes above the ambient temperature, or the present ambient temperature may be entered as the reference temperature. In this case the entered hot junction temperature will be absolute temperatures.
- 2) The reference temperature may be entered in either °C or °F units. The units used for display during the actual usage of this mode are determined by those used to enter the hot junction temperature.

The instrument will then return to normal operation, displaying the present output level and status. If the instrument is presently performing a thermocouple simulation, then this data will be used immediately, otherwise this data will be used whenever a temperature to be simulated is entered.



For Thermocouple specifications refer to *Appendix A—Power Output Capacity Specifications*.

## **Deselecting Thermocouple Simulation Mode**

To deselect the thermocouple simulation mode, select for a voltage or current output by pressing the Units/Entry keys (V or A). This method offers the ability to view the actual output level being used for the Thermocouple Simulation.



## Using the Memory Options

The option called MEM is a 10-step memory, which allows you to program up to 10 output levels. These levels may be recalled speedily from either the front panel or by the rear panel mounted contact closure input.

The ten memory steps are automatically stored in electronic nonvolatile memory. Thus, the stored data are maintained during removal of power from the instrument, including discharge of the internal battery.

### Memory Organization

The memory steps are numbered (in order) from 0 to 9 inclusive. Each of the 10 programmable memory steps may contain the following data:

- Whether the step is Active or Inactive. If a step is flagged as Inactive, the remaining data within the step is maintained but a recall of the memory steps will skip this step.
- The required output level multiplier to be used for display.
- The required output units.
- Any output within the capability of the instrument may be programmed. The multiplier used during the entry (if any) will be used to format the displayed output level when recalled.
- Whether the output is to be placed in the “Operate” or “Standby” state when the step is recalled.

### Front Panel Memory

The front panel memory steps may be either edited or recalled by initially pressing the MNU key.

## Editing Memory Steps

1. Press the MNU key twice. The display now shows the choice:

**< Edit Memory >**

2. Press any of the ENTER keys to select this choice. The display now shows the prompt for the memory step number to be edited, for example:

**< Press Memory 5 >**

3. You may press the CLR or MNU keys at this time to terminate the procedure. Press the numeric key corresponding to the memory to be edited. The display now shows the present status of the selected memory step, either:

**< Inactive >**  
or  
**< Active >**

4. The displayed status of the memory step may be toggled by pressing any of the arrow keys or the MNU key. When the desired status is shown, press any of the ENTER keys to select. If the Inactive state was selected, the display will return to the prompt (step 2 above):

**< Press Memory 5 >**

5. The display then shows the presently stored output level, multiplier and unit. The memory step number being edited is shown in the right-hand end of the display.
6. You may now enter the desired output level into the memory step. The multiplier used during this entry (if any) will be used for formatting the display following recall of the step. The entry is terminated when a valid Units/Enter key (V, A, °C or °F) is pressed. The display now shows the present selection as to whether the instrument will be in the "Operate" or "Standby" state following recall of the step. The memory step being edited is shown in the left-hand end of the display.
7. You may toggle the displayed status for the memory step by pressing any of the arrow keys or the MNU key. When the desired status displays, select it by

pressing any of the Units/Enter keys. The display is then returned to the “Press Memory” prompt, as shown in step 2 above.

## Recalling Memory Steps

Front panel memory steps may be sequentially recalled by following the procedure shown below.

1. Press the MNU key and arrow key until the display shows the selection:

**< Select 1st Mem >**

2. Press any of the ENTER keys. If all memory steps had previously been programmed as *Inactive*, then an error message is displayed and no memory step is recalled. Otherwise, the lowest numbered memory step which has been previously programmed as *Active* will be recalled.
3. When the present output level has been recalled from a memory step, the step number is displayed in the right-hand end of the display (except when the output level is being adjusted). You may select the next higher numbered *Active* memory step by pressing the 8 ▲ (up arrow) key, or the next lower numbered *Active* memory step by pressing the 2 ▼ (down arrow) key.
4. Return the instrument to normal operation by pressing the MNU key. The display will show the choice:

**< Exit Mem Mode >**

5. Now press any of the Units/Enter keys.

## Rear Panel Memory

You may sequentially recall memory steps by closing contacts between the connections to the rear panel contact closure input. This input has a nominal open circuit voltage of 5V DC with a nominal source impedance of 4.7K $\Omega$ , and is debounced for 50ms at both closure and release. Note that closure will initiate selection of the next *Active* memory step or the lowest numbered memory step (if none is presently in use). These contacts are electrically isolated from the output terminals of the instrument. This rear-panel connector is located in the upper, center and is a 0.101 sub-miniature phono socket. The recommended mating plug is obtainable from Switchcraft® as part number 850. The connector is provided

with each instrument as standard and when MEM is ordered. (Vitretek part number *C109001001000001*).

## **General Memory Considerations**

### **Memory of Instrument Status**

The contents of a memory step only affect the selection of the “Operate” or “Standby” status when the memory step is initially recalled. To change the state following recall use the method outlined in *Front Panel Operation*.

### **Editing Memory Steps**

The contents of a memory step may be edited at any time, if the memory step being edited is presently in use, then note that the present output level will be updated when the memory step is next recalled.

### **Adjusting the Output Level**

The “Adjust” mode of operation of the instrument may be used in conjunction with recalling memory steps. Recalling a memory step while in this mode sets the actual output level and the nominal output level to that recalled from the memory. In this manner you are not required to deselect “Adjust” mode when sequentially recalling steps from memory.

### **Thermocouple Simulation**

Only the simulation temperature and the temperature units are stored in a memory location. This feature allows you to change thermocouple type or change between *Active* and *Passive Cold Junction Compensation* without reprogramming the memory steps.



## Applications

This chapter describes specialized applications for using the 2000I, 2000M, 2000IN and 2000MN DC power source instruments and some ways to ensure the quality of the power source.

The front panel terminals are used to:

- Provide stable low-level DC voltage and current;
- Calibrate instrumentation found in process control environments and engineering laboratories;
- Compute output;
- Perform as transfer standards of various values; and
- Provide reference sources in instrumentation circuits.

The (2000M) rear panel connector is used to:

- Simulate thermocouple systems; and
- Measure thermocouple output.

### Low-level DC Power

The 2000 instruments have ability to provide 24-hour stable low level (DC) power via the front panel terminals. Voltage stability runs at the 10V level of 2.1ppm and current stability runs at the 1mA level of 6.0ppm.



## Ensuring Stable Voltage Connections

When connecting to a 2000 instrument for low-level DC voltage operation, take care that extraneous thermal E.M.F. voltages are reduced to minimal levels. These thermal E.M.F. voltages may be caused by temperature differentials between the binding posts and the internal ambient in the instrument or by temperature differentials between the connection leads and the binding posts.

- Ensure that no drafts are present across the front panel terminals, particularly from air conditioning or heating outlets, as these can easily cause thermal gradients between the terminals and the internal ambient in the instrument.
- Use high quality, high purity copper wiring to connect to the front panel terminals and ensure the thermal mass of each lead is similar. The effects of drafts are dramatically increased if materials other than copper and variations in gauge are used.
- If connections are made using direct wires (i.e., terminal clamps) then:
  - ✓ Use the thinnest wire possible (26 AWG or smaller) to reduce thermal mass. The temperature of the thinner wire easily matches the terminal. This wire additionally reduces the effect of drafts due to the reduction of thermal shunting from the internal ambient of the instrument.  
—Or—
  - ✓ Use very heavy gauge wire (16 AWG or larger), achieving the same effect by pulling the terminal to the same temperature as that of the wire.
- Avoid using standard, commercial banana jacks. Vitrek ensures the SP48 and PL36 options are manufactured from highly pure copper and gold plating, ensuring they exhibit low thermal effects.
- Take care to reduce the effects of interference when connecting the 2000 instruments to equipment that has little line frequency rejection, or in environments where non-line frequencies may be injected into the connections.
- Commercial coaxial cable may be used for extreme cases of interference; however, the effects of thermal E.M.F. voltages will degrade performance. In these cases the Vitrek SP48 option is recommended for low thermal effects.

- In most circumstances, the use of a tightly twisted pair of 28AWG wires is recommended, as this both reduces the effects of thermal E.M.F. voltages and achieves the close coupling required to reject interference.
- Route all line wiring and any digital wiring as distant as possible from the analog instrument connections (particularly computer interface and networking cables). For routing distances greater than three feet, use a shielded cable or twisted pair to connect to the terminals.

When the instrument is driving a load, consider the impedance of the wiring. With a 10mA load, the cabling will drop  $\mu\text{V}$  for every  $0.1\text{m}\Omega$  of cable resistance. Check that sufficient wire gauge is used and that the connections to the terminals are clean and tight.

## Ensuring Stable Current Connections

The considerations for low-level DC currents are similar to those for voltages, but thermal E.M.F. voltages and lead resistances have no effect on performance. The primary effects in this mode of operation are those of interference, cable leakage and dielectric storage.

- The effect of interference on low level currents is far more pronounced than for DC voltages.
- For high performance use tightly coupled twisted pairs and/or shielded cables. When using shielded cables, note that while electro-magnetic interference is essentially eliminated, the capacitive injection is eliminated in the center conductor of the cable (only). The twisted pair balances the injection thus has less effect.
- Some instrumentation has far different noise rejection characteristics in one terminal than the other—commonly, one terminal is the virtual earth of an amplifier. Reverse the connections to find the best orientation, particularly when shielded cables are being used.

- When dealing with low-level DC currents at high compliances, the effects of leakage currents become dominant. To limit leakage use the correct insulation throughout the cabling, and keep all connectors and front panels free of grease and dirt. Note that most low-level leakage currents are non-ohmic in nature and tend to be a constant current leakage for compliances above a few hundred millivolts. Insulators with high-insulation resistance ratings measured at several hundred volts may not exhibit this performance when operated at low levels.
  - ✓ For general use P.T.F.E. (known as Teflon®) is effective for low leakage performance. Keep free of grease.
  - ✓ For high compliance voltages use Polyethylene or Polypropylene to lessen the effects of dielectric storage, which results in long settling times. Polyethylene is the insulation used in most high-quality shielded cables.
  - ✓ To eliminate leakage problems without long settling times use non-insulated wiring and maintain an air gap between wires. However, this method may cause excessive interference problems if the cables are long or the environment is particularly adverse.
- Route connecting cables with regard to line wiring. Low-level DC currents are sensitive to interference where high impedance levels are involved. In extreme cases the connection of a high quality Polypropylene capacitor (usually 10nF) across the terminals of the instrument may be used, but the effect on settling time (particularly at high compliances) must be considered.
- A primary source of interference is the movement of personnel near the cables. This effect is caused both by the perturbation of the line frequency field near the person and the direct change in capacitance between the person and the cabling. These effects are reduced by using shielded or twisted pair cables, and may be further reduced by employing anti-static procedures in the surrounding environment to reduce the DC potential between the moving person and the cabling. In general, the only method of eliminating this problem is to avoid excessive movement near the cables, and to keep these cables as short as possible.

### **Low-Level Application Summary**

- To reduce thermal E.M.F. voltage interference to acceptable levels:
  - ✓ Use twisted pairs of 26 AWG (or smaller) wire.

- ✓ Use the Vitrek option SP48 shielded lead set.
- To reduce current interference to acceptable levels:
  - ✓ Use twisted pairs of 26AWG (or smaller) wire with Teflon® insulation.
  - ✓ Use Polyethylene insulated shielded cables or short lengths of bare wire.
- In both voltage and current low-level applications, reduce the movement of personnel near the instrument and cabling to a minimum, and place all line wiring and digital cabling at a distance from the analog signal cables or wires.

## Process Control Industry Applications

The 2000 instruments can be used in the process control industry:

- For calibration and maintenance applications.
- Wherever an accurate source of DC voltage or current is required.
- As a strain gauge bridge simulator with bridge supplies and as a RTD thermometer bridge simulator with bridge supplies.
- As an external DC supply in remote sites.
- As an accurate simulator of most transducers.

## Calibrating in Process Control Environments

The 2000 instruments may be used to calibrate low-level DC voltage or current equipment, such as, chart recorders, nullmeters, galvanometers, analog to digital and digital to analog convertors. The 2000 instruments meet the in-field calibration requirements of the process control industry.

**Caution:** Connecting the 2000 instruments to an active process control system may adversely affect that system's safety. Note that the 2000I and 2000M instruments do not have intrinsic safety certification for process control systems.

## Using the Adjust Mode to Check Calibration

For this application the “Adjust” mode of operation is used to measure the error of the equipment being tested. To test, simply set the calibrator to the required output level and then adjust the output level until the equipment being calibrated reads the correct value. The display of the calibrator will then show the actual error of the unit. When one unit has been calibrated, remove the calibrator from the “Adjust” mode. The output level will then revert to the nominal output level in readiness for calibration of the next unit.

### Calibrating Transducer Systems:

Connect the 2000 instrument in parallel with a 4 – 20mA or a 1 – 5V transducer output to modify the transducer’s indicated output.

### Adjusting Calibration of Multiple Units

The drive capabilities of the 2000 instruments are sufficient to adjust the calibration of multiple units of equipment simultaneously. In voltage mode this is achieved by connecting all the units to be calibrated in parallel. 10 to 20 units can be adjusted simultaneously at voltages above 220mV. At voltages below 220mV the 50Ω output impedance of the 2000 instruments becomes significant.

If the units being adjusted have 10MΩ (or lower) input impedance then a correction has to be made for the output impedance of the 2000 instrument.

- The output impedance of the 220mV range is **45.048Ω • 0.1%**
- The output impedance of the 22mV range is **49.998Ω • 0.1%**.
- Thus the correction required to allow for the input impedance of the units being adjusted is: **Correction =  $(Z_O + Z_{IN}) / Z_{IN}$** 
  - ✓ Where the required output voltage should be multiplied by Correction.
  - ✓ **Z<sub>O</sub>** is the actual output impedance of the 2000I or 2000M instrument.
  - ✓ **Z<sub>IN</sub>** is the combined input impedance of the instrument being adjusted.
- The increase in the limits of error due to applying this correction is: **Error =  $( ( 1000 + EZ_{IN} ) * Z_O ) / Z_{IN}$**

- ✓ Where  $E_{Z_{IN}}$  is the tolerance of the input impedance (in ppm, 1% = 10000ppm).
- ✓ Where *Error* is the increase in the limits of error (in ppm).

Thus, if the combined input impedance is  $1M\Omega \cdot 0.1\%$ , at an output level of 100mV the increased uncertainty is an insignificant: 0.09ppm, and the correction is 1.00004505—an increase in the output level requested of 45.05ppm.

### Setting Scale and Offset Factors for Computed Output Mode:

The equation used by the 2000 instruments to compute the output level from entered data while operating in this mode, is:

$$\text{Output level (scale factor * entered data) + offset factor}$$

The instruments automatically calculate scale factor and offset factor from the data at points A and B as follows:

$$\begin{aligned} \text{Scale factor (outputB - outputA) / (userB - userA)} \\ \text{Offset factor = outputB - (scale factor * userA)} \end{aligned}$$

The 2000 instruments simulate a 4 - 20mA loop whose output corresponds to a pressure span of 50 to 150psi:

$$\begin{array}{ll} \text{outputA} & = 4\text{mA} & \text{userA} & = 50\text{psi} \\ \text{outputB} & = 20\text{mA} & \text{userB} & = 150\text{psi} \end{array}$$

After entering this data (selecting “Calculated Output” mode), enter data in the units of psi, the 2000 instrument will then output the corresponding current (e.g., for an entry of 100psi, the output is 12mA). Note that any Units/Enter keys (V, A, °C or °F) may be used to enter data while in this mode.

The 2000 instruments can be operated in parallel with a sending unit of a transducer having the above characteristics. Use the instrument to modify the transducer indication by entering the data entry as given above, except with the 4mA offsets removed. Thus  $output_A$  and  $output_B$  will be 0mA and 16mA respectively, and  $user_A$  and  $user_B$  will be 0psi and 100psi respectively. The instruments output

the required correction, in the units used by the transducer. Note that this correction may be of either polarity.

**Note:** The entered data are non-volatile, thus they may be entered at your base location, and then be used at a remote site without the need to reenter these data. Refer to *Using the Memory Options*.

## Adjusting Current Measuring of Multiple Units

The 2000 instruments may be used to adjust multiple-current measuring equipment simultaneously. This is achieved by connecting the units in series. Here the 18V compliance capacity of the 2000 instrument allows for as many as 15 units to be adjusted simultaneously. When connecting line-powered current measuring equipment in series check for excessive leakage-current flowing from an input terminal to ground. Current leakage does not affect the measurement when a single unit is connected, but each unit will affect the indications of others when connected in series.

Also many highly-sensitive current measuring devices have inferior rejection to interference on one of their input terminals. When connected in series the interference generated by one unit can adversely affect the performance of the next. To operate multiple units in series, test for loss of accuracy during this procedure. Before adjusting any equipment check the calibration of each unit individually, then connect the equipment in series and recheck.

**Note:** The low output impedance of the 220mV and 22mV ranges of the 2000 instruments enable a small correction factor to be easily applied when the instrument is driving low load impedances.

## Simulating Thermocouple Systems

2000M and 2000MN instruments can be used to simulate single and dual junction thermocouple systems. This instrument offers the choice of using the internal cold junction compensation or using an external high accuracy ice-point reference junction. When using internal cold junction compensation to achieve thermocouple simulation, the accuracies approach 0.1°C. When using external ice-point reference junction to achieve thermocouple simulation, accuracies approach 0.02°C

The 2000M and 2000MN instruments simulate the thermocouple system by computing the *hot* and *reference* junction-E.M.F. voltages from the N.I.S.T. tables with linear interpolation. The output level is set to the difference between these two levels ( $V_{\text{HOT}} - V_{\text{REF}}$ ). Thus single thermocouple (uncompensated) systems can be simulated by setting the cold junction simulation temperature to 0°C using the “Passive CJ” mode.

Select the “Active CJC” mode of operation in the 2000M or 2000MN instrument, and connect the equipment being calibrated to the rear panel connector using the correct thermocouple wire (verify polarity). The instrument will automatically measure and compensate for any ambient temperature at the actual junction between the connecting thermocouple and the CJC #80-BARS.

- ***To set up thermocouple simulation:***

1. Select the thermocouple type: B, E, J, K, N, R, S or T;
2. Choose active or passive cold junction compensation;
3. Enter the required hot junction simulation temperature in either °C or °F units.

**Note:** In cases where an external reference junction exists, and this junction has a known temperature with an accuracy of better than 0.1°C, the 2000M or 2000MN should be operated in the PASSIVE CJC mode.

## Measuring Thermocouple Outputs

The 2000M or 2000MN also offers thermocouple measurement capabilities. You can calibrate both the receiver and the thermocouple itself.

- ***To measure a thermocouple output:***

1. Select the desired thermocouple type and cold junction compensation method.
2. Connect the thermocouple to the 2000M or 2000MN instrument.
3. Select the “Standby” state.
4. Select the Measure mode of operation.



## Engineering Laboratory Environment Applications

The 2000 instruments have many uses in the Calibration and Engineering Laboratory environments.

### Short-Term Transfer Standards

The 2000 instruments can be used for medium accuracy transfers in the calibration laboratory based on their:

- DC voltage 24-hour stability (at the 10V level) of 2.1ppm, and
- DC current 24 hour stability (at the 1mA level) of 6.0ppm,

The excellent low level stability of these instruments also enables them to be used as a bucking type of source for inter-cell comparisons with 0.2 $\mu$ V uncertainty below 22mV. Refer to Table 1.

The short-term stability for current output enables the use of the 2000 instruments for resistance transfers. In this application the 2000I or 2000M instrument is set to a suitable current for the resistance to transfer—a 10V drop across the resistor. A high accuracy digital voltmeter is used to measure the voltage drop across the standard. On the same the standard resistor is then replaced by a resistor of unknown value (one within a 10:1 ratio of the standard).

The value of the unknown resistance is then given by the formula:

$$R_{\text{unknown}} = R_{\text{standard}} * (V_{\text{unknown}} / V_{\text{standard}})$$

Note that this method yields better performance, at higher values, than the normally used practice of placing the two resistors in series and measuring the voltage across each resistor. This is because the voltmeter usually has leakage current flow to ground in one terminal (usually the LO terminal), which unbalances the circuit for the two measurements. In this method, the circuit is in the same conditions for each measurement, thus this effect is eliminated. The major item affecting accuracy is the finite output impedance of the current source, which is only of importance when the two resistor values are significantly different.

The 2000 instruments have an output impedance greater than  $10^{11}\Omega$ , thus this affect is not of importance for unknown values below  $1M\Omega$ . The following table gives the uncertainty of the transfer for various values of standard and unknown resistors. See Note following table.

Table 1: Resistance Values for Transfer

STANDARD	UNKNOWN	CURRENT	BASIC UNCERTAINTY	UNCERTAINTY WITH 1PPM + 1 $\mu$ V DVM STABILITY
100 $\Omega$	10 $\Omega$	20mA	5.75ppm	11.25ppm
10 $\Omega$	100 $\Omega$	20mA	5.75ppm	7.25ppm
1K $\Omega$	100 $\Omega$	10mA	6.5ppm	8.5ppm
1K $\Omega$	1K $\Omega$	10mA	6.5ppm	7.6ppm
10K $\Omega$	1K $\Omega$	1mA	6.1ppm	8.1ppm
10K $\Omega$	10K $\Omega$	1mA	6.0ppm	7.1ppm
100K $\Omega$	10K $\Omega$	100 $\mu$ A	7.5ppm	9.5ppm
100K $\Omega$	100K $\Omega$	100 $\mu$ A	6.5ppm	7.6ppm
1M $\Omega$	100K $\Omega$	10 $\mu$ A	20ppm	22ppm
1M $\Omega$	1M $\Omega$	10 $\mu$ A	10ppm	11.1ppm
10M $\Omega$	1M $\Omega$	1 $\mu$ A	137ppm	139ppm
10M $\Omega$	10M $\Omega$	1 $\mu$ A	37ppm	38.1ppm
100M $\Omega$	10M $\Omega$	0.1 $\mu$ A	1300ppm	1300ppm
100M $\Omega$	100M $\Omega$	0.1 $\mu$ A	307ppm	308ppm

**Note:** The *Basic Uncertainty* figures in this table are those associated with the instrument's stability only, while the overall uncertainty figures are those including 1ppm + 1 $\mu$ V uncertainty for the voltmeter, which can be achieved with a high precision DVM, e.g., Hewlett-Packard 3458A. Note also that, in a standards laboratory environment, up to 2:1 better uncertainties are readily attainable from the 2000 instruments.

---

## Other Laboratory Applications:

1. Variable voltage or current reference source:  
The 2000 instruments may be used as voltage and current reference sources in most instrumentation circuits, enabling the measurement of reference sensitivity and related effects. The low noise of battery power injects little noise into the circuitry.
2. Floating voltage or current sources:  
The 2000 instruments are able to float up to 500V from ground potential without danger and with almost no DC or AC leakage to ground or line.
3. Testing circuitry controlled by DC voltages or currents:  
The 2000 instruments test circuitry, such as, Voltage Controlled Oscillators, etc. Their low, wide-band noise output combined with the battery power and high rejection of injected noise, enable them to perform testing tasks usually done with standard AC powered calibration equipment. The “Adjust” mode of operation enable these circuits to be rapidly tested for linearity by incrementing the output of the 2000 instrument in user defined steps.



# Calibration and Maintenance

This chapter describes the procedures for internal calibration, external calibration, periodic maintenance and internal maintenance of the 2000I, 2000M, 2000IN and 2000MN DC power source instruments.

## Internal Calibration

The internal calibration procedure ensures the 2000 instrument's low-level DC voltage and current specifications are maintained. Perform an internal calibration on a periodic basis at 30 day intervals or less and in conditions where the ambient temperature has changed by more than 5°C. If the instrument is in use as a transfer standard between sites, perform the internal calibration at both sites.

This sequence performs an operational confidence check of the analog and digital circuitry and then performs an internal calibration of the zero offsets. The internal calibration sequence is described below:

- *To perform an internal calibration:*
  1. Press the MNU key. The display will prompt you to select either “Standby” or “Operate” mode.
  2. Select neither mode by continuing to press any of the arrow keys until the INTERNAL CALIBRATION choice is displayed: **< Internal Cal >**
  3. Press any of the Units/Enter keys (V, A, °C or °F) to select Internal Cal.

The instrument then performs the internal tests and calibrations automatically. During these tests and calibrations the display shows the progress, generating warning messages if any out of tolerance or malfunctioning circuitry is detected. After completing an internal cal test, the instrument returns to the output level that was present when the sequence was initiated.

If any errors are detected during the internal calibration and test sequence, the instrument displays a warning message:

- If the error is minor, such as an error not affecting performance, then the message displays for approximately two seconds and the sequence is continued.
- If the error is major, such as an error that seriously affects the performance then the message continuously displays and the sequence is suspended at that stage.

## External Calibration

The 2000 instruments require periodic calibration (e.g., physical adjustment) against external calibration standards to maintain the published specifications. The period at which these calibrations are performed is dependant on your accuracy requirements, as shown in the accuracy tables in *Appendix A-Power Output Capacities*. Vitrek recommends calibration intervals of 90 days, 6 months or 1 year to meet your in house accuracy needs. For example: in some applications, such as, general engineering laboratories and process control environments, the 1 year accuracies may be excessive. In these cases a 3-year interval may be satisfactory.

## Equipment Required to Recalibrate

High precision DC voltage measuring equipment is required to accurately calibrate the 2000 instruments. The objective is an accuracy margin better than those shown in Tables 2 and 3.

Table 2: Voltage Accuracy Margins

INPUT LEVEL	ACCURACY for 90-day specification	ACCURACY for 1-year specification
10V	52 $\mu$ V	92 $\mu$ V
1V	6.5 $\mu$ V	10.5 $\mu$ V
100mV	0.88 $\mu$ V	1.38 $\mu$ V
10mV	0.2 $\mu$ V	0.25 $\mu$ V
0	0.1 $\mu$ V	0.1 $\mu$ V

Examples of equipment with the above capabilities are:

- Valhalla® 2720GS (any version);
- Fluke® 5440B and Fluke 845AB Nullmeter—used together as a measuring device, Fluke 752A reference divider is also recommended, but not required;
- Hewlett-Packard® 3458A Digital DC Ammeter; with opt./A2, manual.
- Solartron® 7081 or Datron® 1281 Digital Multimeters, if recently calibrated at these levels.

**Note:** The accuracy required at a zero input level may be achieved by using the short-term stability of the measuring device, as it simply requires a short circuit to calibrate the measuring device.

The 2000 instruments require current measuring equipment with the accuracy requirements shown in Table 3, for a margin of 2:1 or better. Vitrek recommends using a high-accuracy digital DC ammeter, such as, the Hewlett-Packard 3458A, or a DC voltage measuring device and laboratory standard resistors to achieve the current measurement accuracies. Use standard resistor values of 100Ω, 1KΩ, 10KΩ, 100KΩ and 1000KΩ respectively.

Table 3: Current Accuracy Margins

INPUT LEVEL	ACCURACY for 90-day specification	ACCURACY for 1-year specification
10mA	210nA	315nA
1mA	15.5nA	26nA
100μA	2.1nA	3.2nA
10μA	275pA	400pA
0	25pA	50pA

**Important Note:** The combination of the resistance and DC voltage measurement uncertainty should not exceed the figures shown in Table 2. When calculating the uncertainty of the DC voltage measurement, be sure to include the effects of input impedance (at the 1V DC level) and the input current of the measuring

instrument. Any zero offsets in the measuring system can be compensated for by calibrating the zero current of the system using an open circuit measurement.

## Initiating External Calibration

To initiate an external calibration you may be required to enter a password and/or the common (global) password.

***Important Note:*** *The V or I mode (known state) must be set before performing external calibration or password entry is ignored.*

1. To obtain optimum accuracy, perform an internal calibration immediately prior to initiating an external calibration.
2. To initiate the external calibration procedure: press the MNU key on the front panel and then repeatedly press an arrow key (i.e., 2, 4, 6 or 8) until the display shows the following message:

**< External Cal >**

3. Press any of the Units/Enter keys (V, A, °C or °F) to make the selection. If the instrument has been programmed to require a password for this procedure, you will be prompted with the following display:

**< Enter Password >**

4. If no password is requested the following will display:

**< Start Ext. Cal. >**

5. If a password is required, enter the digits and press a units key (V, A, °C or °F). If the *correct* password has been entered the following will display:

**< Start Ext. Cal. >**

If the *incorrect* password is entered the display will abort after flashing:

**< Wrong >**



**Note:** To abort the external calibration selection at any time, press the CLR key. You will return the instrument to the output level and status that was present when the MNU key was initially pressed.

6. In no password is requested or the correct password is entered, press any of the arrow keys to continue.
7. Whether a password was previously required or not, you may be prompted to enter a new password:

**< New Password >**

- To bypass entering a new password, press any of the arrow keys to continue.
- To enter a password, press any of the Units/Enter keys (V, A, °C or °F). The following will display:

**<Global Password?>**

- To enter a password at this time, press the digits for the new password (up to 10 digits). Press the CLR key to abort, as required. Press any of the Units/Enter keys to place the password in non-volatile storage. Use this entered password for all subsequent external calibrations. If the user presses a Units/Enter key (V, A, °C or °F), having pressed no numeric keys, then a null password is entered, which effectively disables the password protection system.
- If the previously selected password has been lost, use the common password for all 2000 instruments, which is listed on the last page of this user guide. Note that this page/password may have been filed to prevent access. The following will display:

**<Select password>**

8. The instrument is ready to begin the external calibration sequence.

## Performing External Calibration

The instrument automatically selects the next output level and selects the “Adjust” mode of operation, with the least significant digit as the adjustment digit.

## Front Panel Key Adjustments

The ◀ left and ▶ right arrow keys select the adjustment digit, the ▲ up and ▼ down arrow keys adjust the selected digit. To abort any external calibration step press the CLR key. To abort the calibration entirely press the MNU key. To normally end a calibration step—thus entering the adjusted calibration factor, press any of the Units/Enter keys.

**Note:** Pressing a Units/Enter key while the displayed deviation is at zero will effectively skip the procedure to the next calibration point without affecting the calibration factor.

**Important Note:** Take precautions against thermally generated voltages during the execution of the external calibration as extremely low-level DC voltage measurements are required. Be advised of the *Applications* chapter discussion regarding low-level DC voltage connections.

1. Attach the 2000I or 2000M instrument to a recently zeroed nullmeter.

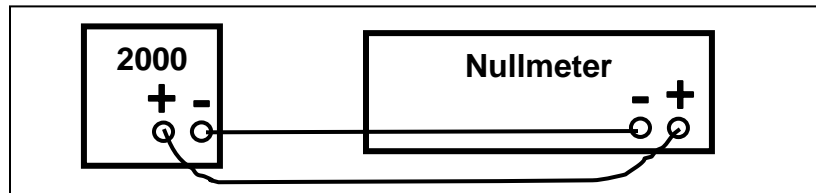

2. Measure the actual output level of the 2000 instrument using the nullmeter. Adjust the instrument, using the arrow keys, until the output level is measured to **0.0μV**, within **0.1μV**, **0.2μV**, **1μV** and **10μV** respectively.
3. Calibrate to an output level of **+10.00000mV**. Adjust the output level of the 2000 instrument to within **0.2μV** of **10mV** as described in step 2.

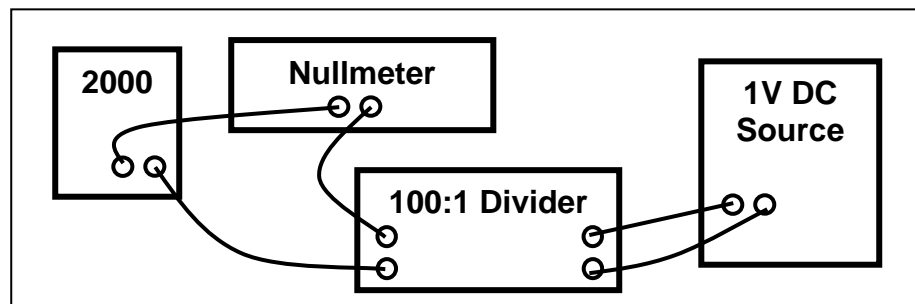

This output level may be measured directly by using:

- ✓ A high precision DMM, or;
  - ✓ A nullmeter to monitor the deviation between this instruments' output level and that of a precision calibrated **10mV** source, or;
  - ✓ The preferred method of using a nullmeter to monitor the deviation between this instrument's output level and the output of a high precision **100:1** attenuator whose input is obtained from a precision calibrated **1V** source.
4. Calibrate to an output level of **+100.000mV**. Adjust the output level to within **0.7 $\mu$ V** of **100mV** as described in step 2.

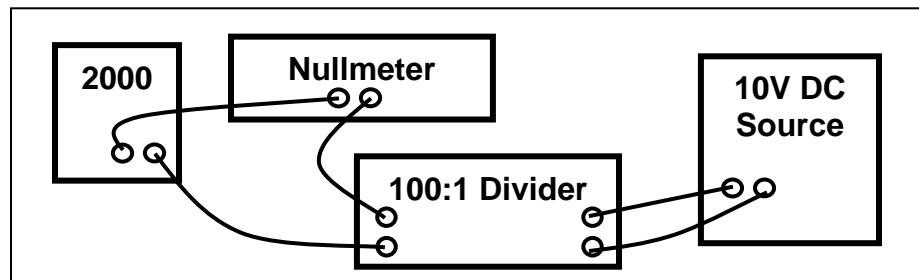

This output level may be measured directly by using:

- ✓ A high precision DMM, or;
  - ✓ A nullmeter to monitor the deviation between this instrument's output level and that of a precision calibrated **100mV** source, or;
  - ✓ The preferred method of using a nullmeter to monitor the deviation between this instrument's output level and the output of a high precision **100:1** attenuator whose input is obtained from a precision calibrated **10V** source.
5. Calibrate to an output level of **+1.000000V**. Adjust the output level of the instrument to within **6 $\mu$ V** of **1V** as described in step 2.

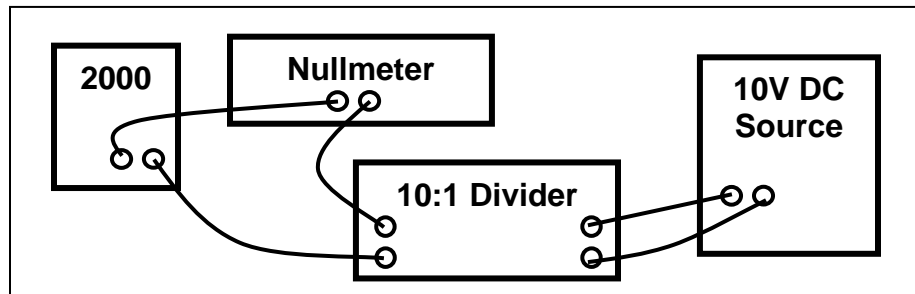

This output level may be measured directly by using:

- ✓ A high precision DMM, or;
- ✓ A nullmeter to monitor the deviation between this instrument's output level and that of a precision calibrated **1V** source, or;
- ✓ The preferred method of using a nullmeter to monitor the deviation between this instrument's output level and the output of a high precision **10:1** attenuator whose input is obtained from a precision calibrated **10V** source.

6. Calibrate to an output level of **+10.00000V**. Adjust the output level of the 2000 instrument to within **60 $\mu$ V** of **10V** as described in step 2.

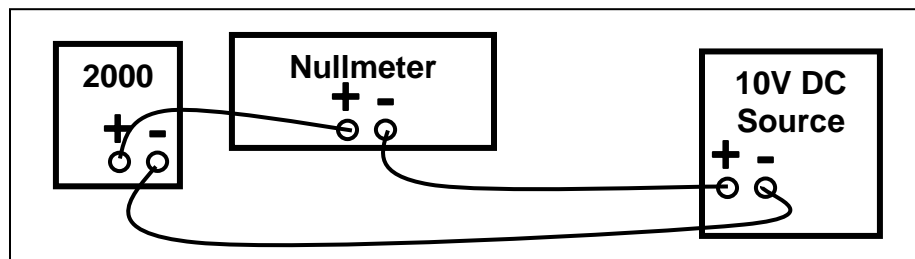

This output level may be measured directly by using:

- ✓ A high precision DMM, or;
- ✓ The preferred method of using a nullmeter to monitor the deviation between this instrument's output level and that of a precision calibrated **10V** source.

7. Calibrate to an output level of **-10.00000V**. Adjust the output level of the 2000 instrument to within **60 $\mu$ V** of **10V** as described in step 2.

This output level may be measured directly by using:

- ✓ A high precision DMM, or;
- ✓ The preferred method of using a nullmeter to monitor the deviation between this instrument's output level and that of a precision calibrated **10V** source.

8. Calibrate to an output level of **0.00000 $\mu$ A**. Adjust the output level of the 2000 instrument as described in step 2, until the voltage measured is: **0.0  $\pm$  2.5 $\mu$ V**, i.e., a current level of **0  $\pm$  25pA**.

This output level may be measured directly by using:

- ✓ A calibration standard **100K $\Omega$**  resistor and a high precision DMM, or;
- ✓ A nullmeter to monitor the voltage drop across the standard resistor

9. Calibrate to an output level of **1.0000 $\mu$ A**. Adjust the output level of the 2000 instrument as described in step 2 until the voltage measured is: **100mV  $\pm$  7.5 $\mu$ V**, i.e., a current of **1 $\mu$ A  $\pm$  75pA**.

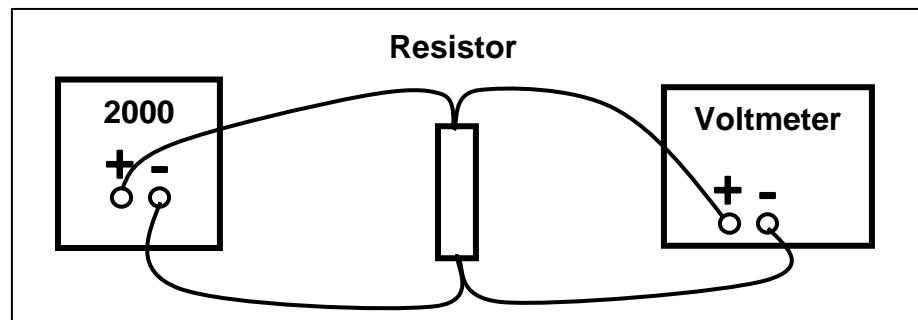

This output level may be measured directly by using:

- ✓ A calibration standard **100K $\Omega$**  resistor and a high precision DMM, or;
- ✓ A nullmeter to monitor the voltage drop across the standard resistor.

10. Calibrate to an output level of **10.000 $\mu$ A**. Adjust the output level of the 2000 instrument as described in step 2 until the voltage measured is: **100mV  $\pm$  5 $\mu$ V**, i.e., a current of **10 $\mu$ A  $\pm$  500pA**.

This output level may be measured directly by using:

- ✓ A calibration standard **10K $\Omega$**  resistor and a high precision DMM, or;
- ✓ A nullmeter to monitor the voltage drop across the standard resistor.

11. Calibrate to an output level of **100.00 $\mu$ A**. Adjust the output level of the 2000 instrument as described in step 2 until the voltage measured is **100mV +/- 10 $\mu$ V**, i.e., a current of **100 $\mu$ A +/- 10nA**.

This output level may be measured directly by using:

- ✓ A calibration standard **1K $\Omega$**  resistor and a high precision DMM, or;
- ✓ A nullmeter to monitor the voltage drop across the standard resistor.

12. Calibrate to an output level of **+10.00000 $\mu$ A**. Adjust the output of the 2000 instrument as described in step 2, until the voltage measured is **1.0V +/- 25 $\mu$ V** (assuming exact resistance of 100K $\Omega$ ), i.e., a current of **10 $\mu$ A +/- 250pA**.

This output level may be measured directly by using a calibration standard **100K $\Omega$**  resistor and a high precision DMM to monitor the voltage drop across the standard resistor.

13. Calibrate to an output level of **+100.0000 $\mu$ A**. Adjust the output of the 2000 instrument as described in step 2, until the voltage measured is **10V +/- 20 $\mu$ V** (assuming exact resistance of 10K $\Omega$ ), i.e., a current of **100 $\mu$ A +/- 2nA**.

This output level may be measured directly by using a calibration standard **10K $\Omega$**  resistor and a high precision DMM to monitor the voltage drop across the standard resistor.

14. Calibrate to an output level of **+1.000000mA**. Adjust the output of the 2000 instrument as described in step 2, until the voltage measured is **1.0V +/- 15 $\mu$ V** (assuming exact resistance of 1K $\Omega$ ), i.e., a current of **1mA +/- 15nA**.

This output level may be measured directly by using a calibration standard **1K $\Omega$**  resistor and a high precision DMM to monitor the voltage drop across the standard resistor.

15. Calibrate to an output level of **+10.00000mA**. Adjust the output of the 2000 instrument as described in step 2, until the voltage measured is **1.0V +/- 20 $\mu$ V** (assuming exact resistance of 100 $\Omega$ ), i.e., a current of **10mA +/- 200nA**.

This output level may be measured directly by using a calibration standard **100 $\Omega$**  resistor and a high precision DMM to monitor the voltage drop across the standard resistor.

16. The next calibration point will be to measure **zero (0.0) VDC**. Attach a small piece of #24 AWG buss wire to the output terminals and allow at least two minutes for the reading to settle.
17. The final calibration point will be to measure **0.1VDC**. Remove the buss wire and apply **0.1VDC** to the output terminals. Allow at least two minutes for settling.
18. No further calibration steps are required. The instrument will now store the calibration factors obtained during this procedure and then select the “Stand-by” state with the power on default output level.

**Note:** Laboratory standard resistors are not normally the exact nominal value. The actual measured voltage drop used for each DC current calibration step will require adjustment for the actual value of the resistor.

$$V_{\text{MEASURED}} = I_{\text{REQUIRED}} * R_{\text{ACTUAL}}$$

## Periodic Maintenance

The 2000I(N) and 2000M(N) DC power source instruments require little periodic maintenance; however, Vitrek makes the following recommendations:

1. Allow the internal battery to fully discharge, and then fully recharge at least once a year. This will ensure that the battery retains its storage capacity.
2. Clean the external surfaces of the chassis with a soft damp cloth. Do not clean the front panel with Freon based cleaning solutions. Take care that moisture does not enter the chassis during cleaning. If the external surfaces become ex-

cessively dirty or damaged, contact Vitrek Customer Service (or one of its agents) for details on how to rectify this situation.

3. If the instrument is to be stored for extended periods of time, fully charge before storing. This will ensure that the battery will accept a full charge when removed from storage.

## Internal Maintenance

In general, the 2000I and 2000M DC power source instruments do not require internal maintenance. In the event of a failure, a calibration fault, or when the internal battery requires replacement, however, the instrument may require opening.

**Important Note:** The information provided here allows you to replace the battery. If you wish to perform detailed fault finding within this instrument, obtain the MS2000 option Vitrek.

**Caution:** The 2000 instruments contain delicate precision circuitry; ensure static control procedures are followed while internal maintenance is in progress.

**Warning:** Prior to removing the outside covers of the 2000 instruments, ensure that the external charging unit or power supply is disconnected and check that the front panel's POWER switch is OFF.

- **To obtain access to the instrument's internal circuitry:**

**Note:** Ensure static control procedures are followed during disassembly and reassembly.

1. Remove the **four** lower feet by pulling them horizontally away from the chassis.
2. Remove the **two** cross-head screws exposed by the removal of the feet in step 1.
3. Remove the **two** cross-head screws holding the top of the two halves of the outer chassis covers.
4. Carefully remove **both halves** of the outer chassis covers by pulling them horizontally out and away from the internal chassis.



**Notes:**

- 1) If significant handling is required, disconnect the positive battery lead to prevent discharge.
  - 2) Take note of the location and orientation of each connector cable prior to removal of Microprocessor and Analog boards for ease of reassembly.
  - 3) Handle all boards carefully to ensure the integrity of their fragile circuitry.
5. Locate and remove the **six** cross-head screws that hold the Microprocessor board to the chassis left side (front viewing). Disconnect cables and lift out the board.
  6. Locate and remove the **six** cross-head screws and the **six** nylon washers that attach the Analog board to the brackets on the chassis right side (front viewing). Disconnect cables and lift out the board.
  7. Locate and remove the **four** cross-head screws that hold the Power Supply board to the standoffs mounted on the chassis bottom. Maintain cable connections to this board, as board can be adjusted while connected.

## Replacing the Internal Battery

Sealed Lead-Acid batteries have an excellent operational life; however their ability to retain charge degrades with time, especially at high temperatures. Replacement of the internal battery is recommended after:

- Two years,
- A significant loss of storage ability is noticed,
- The BATT CHG light does not extinguish after 15 hours of charging.

**Caution:** The internal battery should only be replaced by an exact replacement. Obtain a replacement battery from Vitrek.

**Warnings:**

- 1) Sealed lead-acid and Nickel Metal Hydride batteries are normally stored in a charged condition, take extreme care when handling the battery.
- 2) Always handle and dispose of Sealed Lead-Acid and Nickel Metal Hydride batteries in a safe manner, it is recommended that a Local Authorized Battery recycler be used.

- **To replace a battery:**

1. Open the instrument and remove the Microprocessor board as described in the instruction: *To obtain access to the internal circuitry*. Additionally remove the Analog board and loosen the Power Supply board, as required, to assist in replacing the battery.
2. Remove the **two** #6 nuts and corresponding screws that hold the battery strap to the bracket. (Instruments with studs, require only removal of the nuts.)
3. Remove the battery strap and old battery.
4. Install a new battery and reassemble the instrument in reverse order of disassembly instructions. Be careful to replace all cable interconnections, using the same orientation and cable routing as was present prior to disassembly. Ensure the nylon washers are included when reattaching the Analog board.

**Warning:** The printed circuit boards are continuously powered by the battery, use extreme care in handling them. Reconnect the battery cables after reattachment of the boards.

5. Following complete reassembly, fully charge the replaced battery, in accordance with the charging procedures in the *Battery Charging* chapter.
6. Perform an internal and external recalibration on instrument after charging in accordance with the calibration procedures.

## Interface Operation

This chapter discusses the methods used to interface the 2000I and 2000M DC power source instruments using the optional interface connectors RS-BAT and IE-BAT. In general, operation of these instruments via an interface involves the writing and reading of ASCII data to or from the instrument.

In both interfaces, the same characters are used for each command. The only differences between these two interfaces are due to the physical characteristics and the “built-in” commands; defined by the IEEE488 interface. In both instances, the operation of the interface is completely disabled when the rear panel’s INTERFACE ENABLE toggle switch is OFF or when a front panel operation, such as baud rate or address selection, is not initiated.

**Note:** Throughout this section, it is assumed that the user is fully conversant with manual operation of the 2000 instrument.

### RS232 Interface Option

The RS232 option enables the 2000 instruments to be controlled or interrogated by any RS232 interfaced computer or terminal. A modem telephone link enables control or interrogation to be performed remotely. Rates of 1200, 19,200 and 2400 baud may be selected. This interface is fully isolated from the analog circuitry of the instruments for voltages of up to 500V.

When the RS-BAT interface is fitted in the instrument, an additional selection is available when commanded by the MNU key.

## Selecting RS232

- **To select the RS232 data format:**
  1. Repeatedly press the MNU key until the “SET RS232” selection displays.
  2. Press any of the Units/Enter keys (V, A, °C or °F) to select this action. The unit will then display the presently selected baud rate for the RS232 interface.
  3. You may alter the baud by using any of the arrow keys (2, 4, 6 or 8) until the desired rate is shown. Press any of the Units/Enter keys to select a new baud rate.

**Note:** Ensure that the computer is connected to the RS232 port, set to this baud rate and set for 8 bit data with no parity, 1 stop bit and 1 start bit.

With the RS-BAT option there is no defined *remote* or *local* states, thus the instrument will respond to commands from either the front panel or the interface, as applicable.

## RS232 Handshake Lines

The RS-BAT interface is configured to use the RS232 hardware *handshake* lines *RTS* and *CTS* to handshake data. The usage of these hardware handshake lines ensures that data will not be lost due to differences in processing speeds between the 2000 instrument and the computer. Sometimes the particular computer used will not be able to use these handshake lines properly. To prevent *data overrun*, place delays between sending individual command strings.

## IEEE488 Interface Option

The IE-BAT option enables the 2000 instruments to be controlled or interrogated by any IE-BAT interfaced computer. This interface is fully isolated from the analog circuitry of the 2000I and 2000M DC power source instruments for voltages of up to 500V.

## Remote/Local Operation

The IEEE488 interface defines separate “REMOTE” and “LOCAL” states. While in the LOCAL state, which is following the initial application of power, the instrument will only respond to commands from the instrument’s front panel. Placing the instrument in the “REMOTE” state by way of the defined interface command, the instrument will only respond to commands received via the interface or until released into the “LOCAL” state by the defined interface command. In either state, the instrument’s present status can be read by the interface.

If the instrument is in the ‘REMOTE” state and “LOCAL LOCKOUT” has not been commanded, then press the MNU key to return the instrument to the “LOCAL” state.

## Address Selection

When the 2000-IE-BAT option is fitted, an additional item is available from the MNU key; this is the selection of the interface address. This is accessed by pressing the MNU key on the front panel. The last menu selection (press either the MNU key or any of the arrow keys until this selection is displayed) will be the prompt to change the IEEE488 address, if this is selected (by pressing any of the Units/Enter keys) then the present address will be displayed and the user may enter a new address by pressing the arrow keys until the desired address is shown. Press any of the Units/Enter keys to select the displayed address or press the MNU key to abort the entry.

## IEEE488 Handshake Lines

All the timing requirements of the bus interface are handled by the hardware handshake system used by the IEEE488 interface. During decode of a command all further received data are held-off by this hardware handshake until the decode has been completed. If you want to synchronize the activities of the controller and the 2000 instrument in this respect, then use the *SRQ* capabilities of the 2000 instrument. Additionally note that a two-second delay is forced between sending a Device Clear (either DCL or SDQ bus command) and sending data to the 2000 instrument.

## Bus Commands

As previously mentioned, the IEEE488 interface can perform many tasks that the RS232 does not; those used by the 2000 instrument are as follows:

1. Remote/Local Selection. This has been previously described.
2. Device Clear capabilities. The IEEE488 defined Device Clear functions (both selective and global) force the 2000 to perform a power-on reset function.
3. Serial Poll capabilities. The IEEE488 defined serial poll capabilities of the 2000 correspond to the requirements of the IEEE488 standard, the response byte transmitted by the 2000 consisting of 2 bits of information, the remaining 6 bits all being returned as logical 0. The next to most significant bit (with a decimal equivalence of 64) is set if the 2000 instrument is actively asserting the IEEE488 SRQ line, and the least significant bit (with a decimal equivalence of 1) is set if the 2000 has completed actioning the previously received command string
4. Interface Clear capabilities. The IEEE488 standard defines this command, which causes the interface portion of the 2000 instrument to be reset to the power on conditions, aborting any bus activity in progress.
5. Parallel Poll capabilities. The 2000 instrument does not have any Parallel poll capabilities.

## Other IEEE488 Specific Items

Should a handshake sequence be improperly completed during a transfer of data to or from the 2000 interface, and then the 2000 instrument will automatically perform a power on reset sequence. This facility prevents the interface becoming locked out should the interface cable be removed or become faulty during a data transfer.

Also note that the 2000 instrument offers the facility of changing the IEEE488 address via the front panel or via the interface. To protect the interface from entering an undefined state when this occurs, the 2000 instrument will automatically perform a power on reset sequence when this occurs.

## Reading Data Via an Interface

With either interface, you can read the data presently being displayed on the front panel of the 2000 instrument. With the 2000-RS-BAT interface this is achieved by transmitting the @ character to the 2000 instrument, with the IE-BAT interface this is achieved by simply reading the instrument. In either case, the instrument responds by sending a single *space* character, followed by the 16 character display string, and terminating by the *carriage return* and *line feed* characters (with the IE-BAT interface this last character is sent with the *EOI* line asserted).

## Sending Data Via an Interface

Both the RS-BAT and IE-BAT interfaces operate similarly with regards to sending data to the instrument. The only difference is the requirement to place the instrument in the “REMOTE” state when using the IE-BAT interface. Characters transmitted to the interface are stored in a buffer until a *line feed* character is received, or until a character with the EOI line is asserted (in the IE-BAT interface). The received characters are then decoded and actioned.

Up to 30 characters may be stored in the *receive buffer*, which may contain more than one complete command string type, as desired.

## Command Set for the 2000 Instrument

The 2000I, 2000M, 2000IN or 2000MN instrument command sets are split into two groups:

- The commands, which correspond exactly to individual front panel key presses—to allow the same procedure to be followed, whether the instrument is being used locally or remotely. See Table 4
- The shortcut commands—that allow certain commonly used functions to be easily accessed by remote commands. See Table 5.

### Keypress, Simulation Command Characters

The characters received from the interface that correspond to individual front panel keys are shown in Tables 4 and 5.

**Note:** Command types other than those listed in Tables 4, 5 or 6 are always discarded and ignored.

Table 4: Command Characters

Front Panel Key	Characters Received	Front Panel Key	Command Character Received
0	0	. (period)	. (Dec. Pt.)
1	1	+/-	-
2	2	V, Volts, or ENTER	V
3	3	A, Amps, or ENTER	A
4	4	m (milli-)	m
5	5	$\mu$ (micro-)	u
6	6	°C, or ENTER	C
7	7	°F, or ENTER	F
8	8	CLR	E
9	9	MNU	M

When using the IE-BAT interface, each character may be sent with the *EOI* line asserted, in which case the display will show the progress of the command that is being built in this manner.

Table 5: Shortcut Command Character Sequences

Char/Seq	Description of Action
@	Initiates the output of the display data (RS-BAT only)
<i>D</i>	Selects the "Adjust" mode.
<i>I</i>	Commands an internal calibration sequence.
<i>J0</i>	Selects "Passive CJ" (i.e., turns off internal Active CJC) (2000M)
<i>J1</i>	Selects "Active CJC" activity (i.e., turns on internal Active CJC). (2000M)
<i>K0</i>	Deselects the "Calculated Output" mode of operation.
<i>K1</i>	Selects "Calculated Output" mode of operation, using the presently set pair of user defined points and units.
<i>N</i>	Deselects the "Adjust" mode.



Char/Seq	Description of Action
<i>O</i>	Selects the “Operate” state.
<i>P</i>	Commands the interface to assert the <i>SRQ</i> (service request) line when a previously received command has been fully actioned. Applies to UE2000 only.
<i>R</i>	Commands a <i>power-on</i> reset sequence.
<i>S</i>	Selects the “Standby” state.
<i>T</i>	Sets the Thermocouple type to that described by the character immediately following, e.g., “TK” sets the thermocouple type to “K”.
<i>X</i>	Initiates an external calibration, which is equal to selecting “External Cal”.

## Firmware Version F.02 or Newer

The Firmware Version F.02 update to the 2000I, 2000M, 2000IN and 2000MN DC power source instrument models include all the standard capabilities, including “Range Lock” mode, the ITS-90 Thermocouple temperature for the 2000M and 2000MN instruments and an extended command set.

## Extended Command Set

The interface command list includes “Range Lock” and “Measurement” modes. The software version F.02 command set for the 2000 instruments and RS-BAT and IE-BAT interfaces is given in Table 6.

Table 6: Extended Command Set

Command	Description
G0	Deselects the “Measure” mode
G1	Selects the “Measure” mode
L1	Locks the 20 volt Range
L2	Locks the 2 volt Range
L5	Locks the 20mA Range
Tx	Selects thermocouple type x (2000M only)
UA	Unlocks all ranges: voltage and current
U1	Unlocks the 20 volt Range

Command	Description
U2	Unlocks the 2 volt Range
U5	Unlocks the 20mA Range

## Command String Usage

Vitrek assumes the user is conversant with the send and receive data commands when using the actual computer interface and with the language used to control the 2000 instruments. Vitrek also assumes all command strings (those shown enclosed in quotation marks) are followed by the *carriage return* and *linefeed* characters. Note that it is unnecessary to send the quotation mark characters and that the final character is sent with the *EOI* line asserted (UE2000 interface).

## Setting an Output Voltage or Current

Sending the character string "K0+10.0VO" commands the 2000 instruments to output a voltage of +10V. Note that the *K0* portion of this string deselects the Calculated mode to ensure that the instrument is in the "Operate" mode. Voltages of +10.23mV and -3.456 $\mu$ V are similarly commanded by the strings "K0+10.23mVO" and "K00-3.45 $\mu$ O" respectively. Note the condition shown in the later example where negative quantities require numeric entry be started before the entry of a negative polarity (avoiding the polarity character performing a change in the present output polarity), this is readily achieved by sending the 0 character prior to the actual numeric quantity (this may be performed for either polarity of numeric data). Note further that any additional digits beyond the capabilities of the instrument are ignored (thus the output level will actually be set to -3.45 $\mu$ V in the latter example).

Similarly to the voltage output examples shown above, current outputs may be commanded also. For example, if output levels of +20.6543mA, -0.1mA or +10.5 $\mu$ A are required, then the strings "K0+20.6543mA0", "K00-0.1mA0" or "K0+10.5 $\mu$ AO" respectively, would be transmitted to the 2000 instruments.

In these examples, the numeric entry of the output level is achieved by simulation of front panel key presses, thus the same techniques are applicable as defined in the *Front Panel Operation* section of this document.

## Adjusting Output Level

This may be achieved by *shortcut* commands or by simulating keyboard commands by using command characters. To select the “Adjust” mode of operation the instrument may send the character string *D* or the character string *MMV*. In the later character string, note that these characters simulate the key presses required to perform the desired task: MNU, MNU and V, whereas the first command string uses the shortcut form.

Having selected the “Adjust” mode of operation, the user may send any combination of (2, 4, 6 or 8) characters to simulate the down, left, right, and up arrow keypad commands respectively, thus selecting the required digit and incrementing or decrementing it as desired.

## Reading Present Output Level

In each example shown below, the actual output character string is followed by the *carriage return* and *line feed* characters.

The 2000 instruments output level and status may be read at any time, when using the IE-BAT interface. You can *read* via the RS-BAT interface after transmitting the @ character to the 2000I or 2000M instrument and then reading the characters as received from the instrument.

If the output level is **+10.23567V**, in the “Operate” state and not in “Adjust” mode, then the received string will be **+10.23567V**. Note that 19 characters are always transmitted (a leading *space*, the 16 display characters, the *carriage return* character, and the *linefeed* character).

There are many different combinations of output data that are possible, the user is advised to program either the 2000I or 2000M instrument manually and read the display data for each intended operation before programming its software.

## Internal Calibration

You may command an automatic internal calibration of internal zero offsets whenever desired. Remotely command an internal calibration via either interface by sending the command string “*I*”. The progress of the internal calibration can

be obtained (for both interfaces) by reading the 2000 instrument display data as described in the *Maintenance and Calibration* chapter.

The accuracy specifications presented in the Appendix A tables assume the use of this function at least every 30 days, or for a temperature change of greater than 5°C from that at the previous internal calibration.

## External Calibration

You may command an external calibration whenever desired. Remotely command an external calibration via either interface by sending the command string "X". To prevent unauthorized access, an optional password protection scheme is used.

A one-year external calibration interval is recommended for normal use. Reduce this interval if greater accuracies are required. While calibration at 23°C ambient is highly recommended, this may be performed at any temperature from 10°C to 35°C without degradation of accuracy specifications. The accuracy figures in the Appendix A tables are valid for temperatures up to 5°C from this temperature. When used in less accurate applications, the external calibration interval may be extended up to three years; the accuracies achieved are shown in the respective tables.

## Appendix A— Output Specifications

The DC voltage and current output capabilities of the 2000I, 2000M, 2000IN and the 2000MN instruments are provided here. Additionally, specifications for the 2000M instrument's thermocouple measurement and simulation option are included here.

### DC Voltage Output Specifications

The accuracy figures given in Table 7 are valid throughout the temperature range of 18° to 28°C. The 24 hour stability figures are for constant load and temperature (within 1°C) and are measured using a DC to 2Hz bandwidth. The accuracy figures are relative to calibration standards. Add 3ppm + 1μV to the voltage figures, and 15ppm + 20pA to the current figures, for absolute accuracy.

Table 7: DC Voltage Output

Levels	<22mV	22 - 220mV	0.22 - 2.2V	2.2 - 22V
Resolution	10nV	100nV	1μV	10μV
24 Hr. Stability (ppm + μV)	3.0 + 0.08	2.5 + 0.1	1.8 + 0.5	1.8 + 3.0
90 Day Accuracy (ppm + μV)	20 + 0.2	15 + 0.25	12 + 1.0	10 + 4.0
1 Year Accuracy (ppm + μV)	30 + 0.2	25 + 0.25	20 + 10.0	18 + 4.0
Temperature Coefficient P (ppm + μV)	2.5 + 0.03	2.0 + 0.04	1.5 + 0.2	1.5 + 1.0
Pk-PK Noise 0.01 – 10 Hz (ppm+ μV/°C)	0.3 + 0.04	0.3 + 0.06	0.3 + 0.3	0.3 + 2.0
RMS Noise 10Hz – 10KHz	5μV	5μV	7.5μV	10μV

**Note:** To maintain accuracy whenever outside this temperature range, apply the relevant temperature coefficient adder.

Settling Time:----- Less than 2 seconds to within 10ppm of change + 0.25 $\mu$ V

Drive Capability: ----- 15mA max. (50 $\Omega$  output impedance below 220mV, 0.1 $\Omega$  above 220mV)

Overload: ----- Output fully protected against short-circuits

Long-Term Effects: --- Add 25ppm of output to 1 year specification for 3 year accuracy

## DC Current Output Specifications

DC current output is available in both the 2000I, 2000M, 2000IN and the 2000MN instruments. Refer to Table 8.

Table 8: DC Current Output

Levels	< 22 $\mu$ A	22 – 220 $\mu$ A	0.22 – 2.2mA	2.2 - 22mA
Resolution	10pA	100pA	1nA	10nA
24 Hr. Stability (ppm + nA)	7.0 + 0.03	5.0 + 0.15	5.0 + 1.0	5.0 + 15
90 Day Accuracy (ppm + nA)	50 + 0.05	40 + 0.15	30 + 1.0	40 + 20
1 Year Accuracy (ppm + nA)	70 + 0.1	60 + 0.25	50 + 2.0	60 + 30
Temperature Coefficient P (ppm + nA) / $^{\circ}$ C	5.0 + 0.015	5.0 + 0.1	5.0 + 1.0	5.0+1.0
Pk-PK Noise 0.01 – 10Hz (ppm+ nA)	1.5 + 0.02	1.2 + 0.1	0.8 + 0.5	0.8 + 5.0
RMS Noise 10Hz – 10KHz	200pA	750pA	5nA	50nA

Settling Time:----- Less than 2 seconds to within 10ppm of change + 50pA.

Drive Capability: ----- Greater than 18V compliance ability, stable into active and/or inductive loads.

Overload: ----- Output fully protected against open circuits, or applied voltages less than 50V.

Output Impedance: ---- Greater than 10<sup>11</sup> $\Omega$

---

Long-Term Effects: --- Add 60ppm of output to 1 year specification for three year accuracy

## Voltage Measurement Specifications

Voltage measurement capabilities are present in the 2000M instrument. To measure voltage, access the instrument's "Measurement" mode.

In Voltage Measurement mode (-0.15 to +0.15V):

- A 90 day absolute accuracy is 0.01% +1 $\mu$ V +3ppm +1 $\mu$ V throughout the temperature range.
- A 1 year absolute accuracy is 0.02% +1 $\mu$ V +3ppm +1 $\mu$ V throughout the temperature range.

## Thermocouple Specifications

The specifications for Thermocouple simulation and measurements are shown in Table 9. All temperatures are given in °C, the desired temperature may be defined in the instrument in either °C or °F units. The required output voltage is internally computed from the entered temperatures from N.I.S.T. look-up tables for the respective thermocouple type with interpolation. **Note:** Both cold and hot junction temperatures may be entered.

Table 9. Thermocouple Simulation and Measurement Specifications

Type	Simulation Resolution	Measurement Resolution	Measurement Range
B	0.01°C 0.01°C	0.15°C 0.08°C	+200 to +300°C +300 to +1820°C
E	0.01°C 0.01°C 0.01°C	0.15°C 0.05°C 0.01°C	-270 to -260°C -260 to -70°C -70 to +1000°C
J	0.01°C 0.01°C	0.02°C 0.01°C	-210 to -140°C -140 to +760°C
K	0.01°C	0.01°C	-140 to +1372°C
N	0.01°C	0.03°C	-200 to +1300°C
R, S	0.01°C 0.01°C	0.06°C 0.03°C	0 to +200°C +200 to +1768°C
T	0.01°C 0.01°C	0.02°C 0.01°C	-200 to +100°C +100 to +400°C



Table 10a: CJC Stability — Simulation

Type	Range °C	Simulation using Passive CJC					Simulation using Active CJC				
		Stability	Relative Accuracy		Absolute Accuracy		Stability	Relative Accuracy		Absolute Accuracy	
		24 hr	90 day	1 yr.	90 day	1 yr.	24 hr	90 day	1 yr.	90 day	1 yr.
B	200 to 300	0.06	0.11	0.14	0.60	0.65	0.11	0.21	0.29	0.70	0.80
	300 to 700	0.04	0.07	0.09	0.40	0.45	0.09	0.17	0.24	0.50	0.60
	700 to 1820	0.02	0.045	0.06	0.20	0.25	0.07	0.15	0.21	0.30	0.40
E	-270 to -260	0.07	0.12	0.25	0.40	0.55	0.12	0.22	0.40	0.50	0.70
	-260 to -250	0.02	0.06	0.08	0.20	0.25	0.07	0.16	0.23	0.30	0.40
	-250 to -240	0.02	0.04	0.05	0.15	0.17	0.07	0.14	0.20	0.25	0.32
	-240 to -230	0.01	0.03	0.04	0.10	0.12	0.06	0.13	0.19	0.20	0.27
	-230 to 1000	0.01	0.02	0.03	0.07	0.09	0.06	0.12	0.18	0.17	0.24
J	-210 to 760	0.02	0.02	0.05	0.07	0.10	0.07	0.12	0.20	0.17	0.25
K	-140 to 800	0.01	0.02	0.03	0.06	0.07	0.06	0.12	0.18	0.16	0.22
	800 to 1372	0.01	0.035	0.05	0.07	0.09	0.06	0.14	0.20	0.17	0.24
N	-200 to -150	0.02	0.03	0.04	0.13	0.14	0.07	0.13	0.19	0.23	0.29
	-150 to 1000	0.01	0.02	0.04	0.08	0.10	0.06	0.12	0.19	0.18	0.25
	1000 to 1300	0.01	0.03	0.04	0.06	0.07	0.06	0.13	0.19	0.16	0.22
R, S	0 to 100	0.02	0.045	0.05	0.25	0.26	0.07	0.15	0.20	0.35	0.41
	100 to 1000	0.02	0.035	0.05	0.15	0.17	0.07	0.14	0.20	0.25	0.32
	1000 to 1768	0.02	0.06	0.07	0.16	0.17	0.07	0.16	0.22	0.26	0.32
T	-200 to -100	0.01	0.025	0.03	0.08	0.09	0.06	0.13	0.18	0.18	0.24
	-100 to 400	0.01	0.015	0.02	0.05	0.06	0.06	0.12	0.17	0.15	0.21

**Note:**  
 The +3ppm + 1 $\mu$ V  
 absolute accuracy  
 adder for the Vitrek  
 production  
 calibration may be  
 substituted by the  
 accuracy figures of  
 your calibration  
 equipment, changing  
 the absolute accu-  
 racies provided in this  
 table.

Table 10b: CJC Stability — Measurement

Type	Range °C	Measurement using Passive CJC					Measurement using Active CJC				
		Stability	Relative Accuracy		Absolute Accuracy		Stability	Relative Accuracy		Absolute Accuracy	
		24 hr	90 day	1 yr.	90 day	1 yr.	24 hr	90 day	1 yr.	90 day	1 yr.
B	200 to 300	0.11	0.19	0.22	0.68	0.73	0.16	0.29	0.37	0.78	0.88
	300 to 700	0.07	0.17	0.19	0.52	0.57	0.12	0.27	0.34	0.62	0.72
	700 to 1820	0.04	0.25	0.26	0.43	0.48	0.09	0.35	0.41	0.53	0.63
E	-270 to -260	0.12	0.20	0.33	0.48	0.63	0.17	0.30	0.48	0.58	0.78
	-260 to -250	0.04	0.11	0.13	0.28	0.33	0.09	0.21	0.28	0.38	0.48
	-250 to -240	0.03	0.08	0.09	0.19	0.21	0.08	0.18	0.24	0.29	0.36
	-240 to -230	0.02	0.06	0.07	0.13	0.15	0.07	0.16	0.22	0.23	0.30
	-230 to 500	0.02	0.08	0.09	0.15	0.17	0.07	0.18	0.24	0.25	0.32
	-230 to 1000	0.02	0.13	0.14	0.18	0.20	0.07	0.23	0.29	0.28	0.35
J	-210 to 760	0.03	0.10	0.13	0.15	0.19	0.08	0.20	0.28	0.25	0.34
K	-140 to 300	0.02	0.06	0.07	0.10	0.12	0.07	0.16	0.22	0.20	0.27
	300 to 800	0.02	0.11	0.12	0.15	0.17	0.07	0.21	0.27	0.25	0.32
	800 to 1372	0.02	0.18	0.19	0.21	0.23	0.07	0.28	0.34	0.31	0.38
N	-200 to -150	0.03	0.06	0.07	0.16	0.18	0.08	0.16	0.22	0.26	0.33
	-150 to 300	0.02	0.06	0.08	0.12	0.15	0.07	0.16	0.23	0.22	0.30
	300 to 1000	0.02	0.13	0.15	0.19	0.22	0.07	0.23	0.30	0.29	0.37
	1000 to 1300	0.02	0.17	0.18	0.20	0.22	0.07	0.27	0.33	0.30	0.37
R, S	0 to 100	0.04	0.08	0.08	0.28	0.29	0.09	0.18	0.23	0.38	0.44
	100 to 300	0.04	0.09	0.10	0.20	0.22	0.09	0.19	0.25	0.30	0.37
	300 to 1000	0.04	0.16	0.17	0.27	0.29	0.09	0.26	0.32	0.37	0.44
	1000 to 1768	0.03	0.25	0.26	0.35	0.37	0.08	0.35	0.41	0.45	0.52
T	-200 to -100	0.02	0.06	0.06	0.11	0.12	0.07	0.16	0.21	0.21	0.27
	-100 to 400	0.02	0.07	0.07	0.10	0.11	0.07	0.17	0.22	0.20	0.26





## Appendix B— General Specifications

Battery Discharge Time:	8 hours min. after full charge conditions: output unloaded; interface disabled
	6 hours min. after full charge conditions: output loaded, interface disabled
	5 hours min. after full charge conditions: RS232 interface enabled
Battery Charge Time:	12 hours max. to full charge conditions: unit OFF (2000I and 2000M)
	15 hours max. to full charge conditions; unit ON, interface disabled
Charging Module:	Univerasal Input 85Vac -265VAC: DC Output: 12V @ 1.5A Min
Battery Type:	Sealed Lead Acid—Maintenance Free (2000I and 2000M) Nickel Metal Hydride, STD 3800mAH, Main-tenance Free, Additional batteries available, Contact Vitrek customer support for availability.
Battery Charging Signal:	Red LED illuminates on the front panel when internal battery during charging.
Battery Voltage Level:	Green LED illuminates on the front panel when the internal battery has sufficient voltage to power the instrument (2000I and 2000M). On the 2000IN and 2000MN the Green LED will begin to flash to warn the user that the Battery State has depleted to a state that requires that the batteries need to be recharged.

**Note:** The internal circuitry is automatically powered down when the battery voltage is low. Note that when this condition is achieved the only way to repower the instrument is to plug it into the external charger. This will reset the internal circuitry and reconnect the internal battery circuitry.

## Warm-Up Time

The specifications for both V or I mode are valid following a fifteen-minute period after setting the power switch to the *ON* position (assuming a charged battery). For readings involving temperature, a warm-up time of at least 30 Minutes is recommended..

## Environmental

Operating Temperature:	0°C to 50°C
Storage Temperature:	-30°C to 63°C
Humidity:	70% RH max. at 40°C (non-condensing)

## Isolation

- 150V peak isolation to external chassis from output terminals
- 500V peak isolation to ground when charging module or interface is connected.
- 1500V peak isolation between terminals, and from either terminal to chassis/ground, when in “Standby” mode.

## Computation

Both the 2000I,2000M, 2000IN and 2000MN power source instruments can use a computed output level such as an equation  $output = S*entry + 0$ , where S and 0 are user-defined constants. The output may be either voltage or current and you may optionally define displayed units of up to three characters in length using upper- or lower-case characters. Computations are performed with 0.1ppm precision.



**The common password for enabling External Calibration is:**

**10288**

**Place instrument in a known state, such as, current or voltage before entering the password.**

**Note that this page can be removed, as required, to protect this data from unauthorized users.**



